

MBC

MBC-IQ-LAB

IQ Modulator Bias Controller

Exail MBC-IQ-LAB is a bias controller designed to stabilize the three operating bias points of a dual parallel modulator. This MBC is fully automated and uses a reduced dither signal to provide a rock stable setpoint of your phase delays over time and environmental conditions. It has been designed for optimal performance in CS-SSB applications to ensure a robust and steady optical carrier extinction.

Finally, a user-friendly Graphical User Interface - GUI - is provided for monitoring and (manual) setpoint adjustments if desired.



Features

- Designed for I&Q modulators
- Automated bias points (MIN, MIN, QUAD)
- High stability
- High sensitivity

Applications

- Analog communications CS-SSB

Options

- Internal photodiode and tap coupler
- Dual drive IQ modulator

Performance Highlights

Parameter	Min	Typ	Max	Unit
DC bias voltage	-12	-	+12	V
Automated locking points	DC ₁ MIN, DC ₂ MIN, DC ₃ QUAD±			-
Control	Remote			-

Ordering Information:



800 Village Walk #316
Guilford, CT 06437
Ph: 203-401-8093

Email orders to: sales@xsoptix.com
Fax orders to: 800-878-7282

MBC-IQ-LAB

IQ Modulator Bias Controller

Bias Control Characteristics

Parameter	Symbol	Condition	Min	Typ	Max	Unit
Timing						
Autotest	Auto	Automatic scan	-	20	-	s
Initialisation	-	Bias control stabilization time after a scan	-	30	180	s
Efficiency						
Optical output power stability -		Over 2 hours and modulator temperature controlled	-	± 0.1	-	dB

Electrical Characteristics

Parameter	Symbol	Condition	Min	Typ	Max	Unit
DC ₁ , DC ₂ bias voltage	V _{bias}	VDC ₁ , VDC ₂	-12	-	+12	V
DC3 bias voltage	V _{bias}	VDC ₃	-13.5	-	+13.5	V
Locking point	DC ₁	Automated	MIN (0 %)			-
	DC ₂	Automated	MIN (0 %)			-
	DC ₃	Automated	QUAD- (-50 %), QUAD+ (+50 %)			-
Dither frequency DC ₁	F _{DC1}	-	-	1120	-	Hz
Dither frequency DC ₂	F _{DC1}	-	-	840	-	Hz
Dither amplitude	V _{DC1, 2, 3}	-	5	-	1000	mVpp
Dither amplitude step	ΔV _{DC1, 2, 3}	-	1	-	-	mVpp

Optical Characteristics

Parameter	Symbol	Condition	Min	Typ	Max	Unit
MBC-IQ-LAB-A1: MBC with embedded PD and tap-coupler						
Wavelength	λ	-	1530	1550	1625	nm
Insertion loss	IL	-	-	1.4	-	dB
MBC-IQ-LAB-A0: MBC without PD and tap-coupler						
Wavelength	λ	MBC-IQ-LAB-A0	900	-	1600	nm

MBC-IQ-LAB-A0: set-up with an IQ modulator

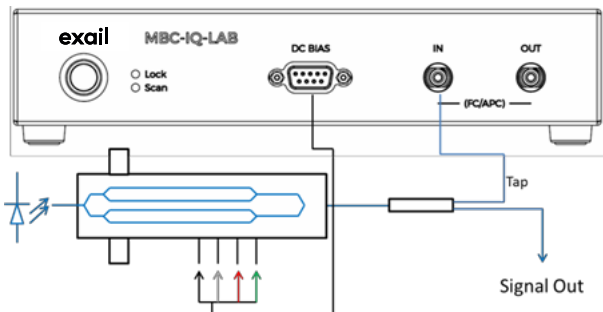

MBC-IQ-LAB-A1: set-up with an IQ modulator

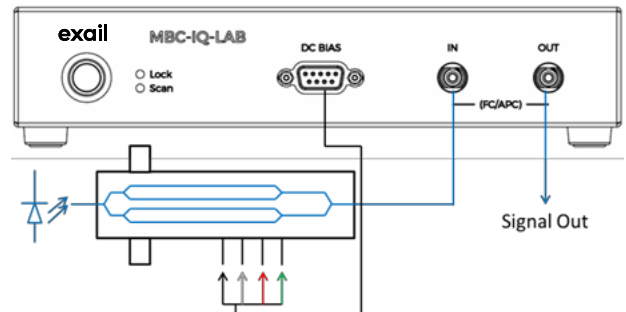

MBC-IQ-LAB

IQ Modulator Bias Controller

Absolute Maximum Ratings

Stresses in excess of the absolute maximum ratings can cause permanent damage to the device. These are absolute stress ratings only. Functional operation of the device is not implied at these or any other conditions in excess of those given in the operational sections of the data sheet. Exposure to absolute maximum ratings for extended periods can adversely affect device reliability.

Parameter	Symbol	Condition	Min	Max	Unit
Operating temperature	-	-	-10	+45	°C
Storage temperature	-	-	-40	+70	°C

Output Power Stability

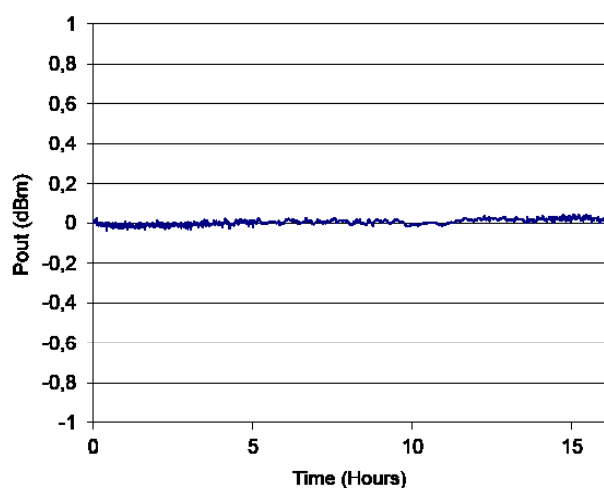

Graphical User Interface

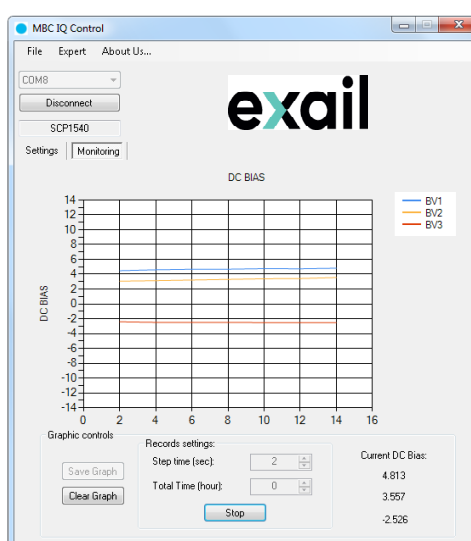

MBC-IQ-LAB

IQ Modulator Bias Controller



Dimensions

Dimensions (W x H x D)	220 mm x 220 mm x 52 mm
Power supply (rear panel)	100 V - 120 V / 220 V - 240 V automatic switch, 50 Hz - 60 Hz

Interfaces

Photodiode Input / coupler input	FC/APC connector
Bias output	Specific DB9 connector to single channel connector
Communication	USB

Remote control

Minimum computer requirements	Windows XP SP3
Computer configuration	Recommended Windows XP-SP3, W7, W8

Ordering information

A0: no coupler, 900 nm to 1600 nm

A1: integrated coupler, 1530 nm to 1625 nm

MBC-IQ-LAB-□

About us

Exail Photonics produces specialty optical fibers and Bragg gratings based fiber optics components and provides optical modulation solutions based on the company lithium niobate (LiNbO₃) modulators and RF electronic modules.

Exail Photonics serves a wide range of industries: sensing and instruments, defense, telecommunications, space and fiber lasers as well as research laboratories all over the world.

Exail reserves the right to change, at any time and without notice, the specifications, design, function or form of its products described herein. All statements, specification, technical information related to the products herein are given in good faith and based upon information believed to be reliable and accurate at the moment of printing. **However, Exail provides no warranty (whether express or implied or statutory) as to the description, sufficiency, accuracy or completeness, merchantability or fitness for a particular purpose of any information or specification detailed herein.** No liability is assumed for any inaccuracies and/or as a result of use of the products. The user must validate all parameters for each application before any use and he shall assume all risks and responsibilities in connection with the use of the products.