

# PM FIBER-Q®

## Polarization Maintaining 1550 nm Fiber Coupled Acousto-Optic Modulator

T-M200-0.1C2J-3-F2P

Gooch & Housego specialize in providing optical components for fiber laser systems.

Gooch & Housego specialize in providing optical components for high power fiber laser and amplifier systems. In-house control of critical manufacturing processes; from crystalline material selection and orientation, cutting, polishing and anti-reflection coating through to fiber coupling, ensure our components are of the highest optical quality.

In addition to the standard product shown, custom configurations are available for specialized applications.



### Key Features

- Low insertion loss
- Compact low profile package
- Rugged hermetic design
- Stable performance
- Custom configurations available

### Applications

- Fiber laser
- Pulse picker
- Optical sensing

POLARIZATION MAINTAINING 1550 NM FIBER COUPLED ACOUSTO-OPTIC MODULATOR

## Preliminary Specifications:

Parameter	Min	Max	Typical	Comments
Interaction material	-	-	-	Tellurium dioxide
Wavelength	1530 nm	1565 nm	1550 nm	Other wavelengths available on request
Average optical power handling	-	1 W	-	
Peak optical power handling	-	1 kW	-	Dependant on pulse width
Insertion loss	-	6.0 dB	5.0 dB	
Polarization extinction ratio	15 dB	-	20 dB	
Extinction ratio (ER)	50 dB	-	-	
Return loss (RF ON/RF OFF)	40 dB	-	-	
Rise-time/fall-time (10% - 90%)	-	10 ns	-	Does not include RF Driver rise / fall time
Frequency	-	-	200 MHz	
VSWR	-	1.5:1	-	
Input impedance	-	-	50 $\Omega$	
RF power	-	2.5 W	-	Absolute maximum rating (Higher power will cause damage)
Frequency shift	-	-	200 MHz	Up-shift
Fiber type	-	-	-	Fujikura PM1550 (SM15-PS-U25A) or equivalent
Fiber length	1.5 m	-	-	900 $\mu$ m PVDF sleeving
Fiber termination	-	-	-	Bare fiber

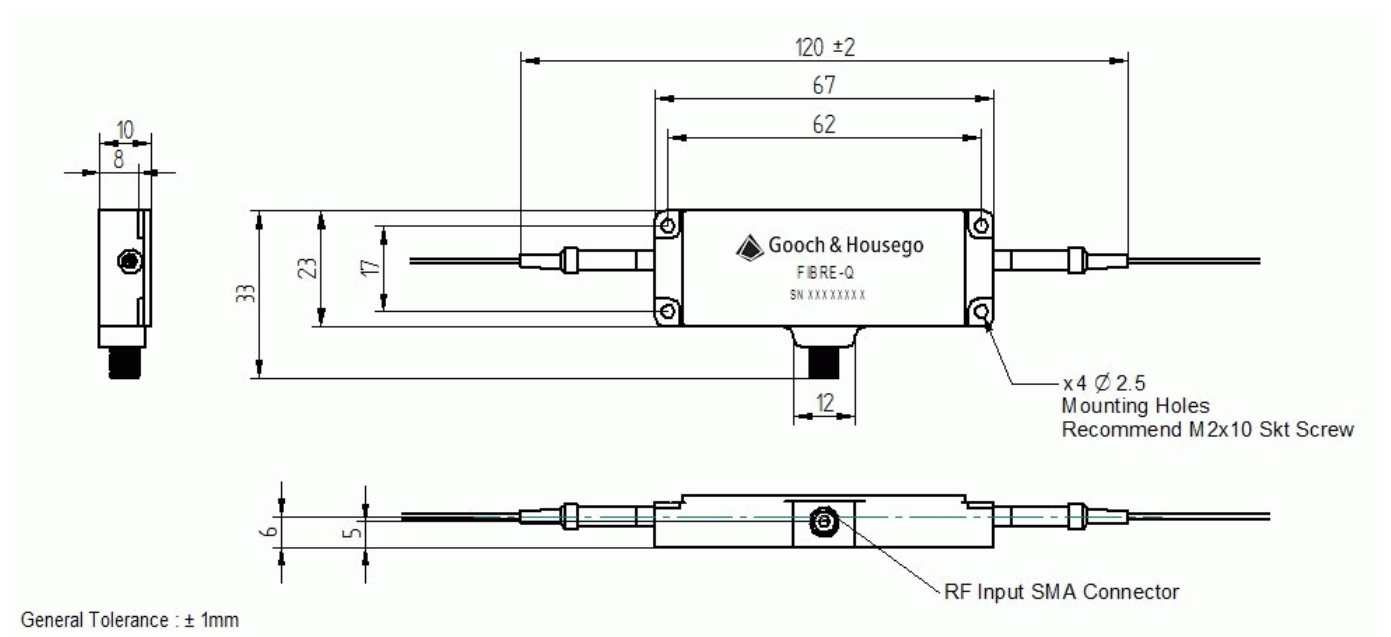

### Other products which may be of interest

- HI REL couplers
- High power multimode combiners
- Combiners with all types of signal feedthrough fiber
- Ultra-low ratio tap couplers
- WDMs for combining signals with red pointer lasers
- OCT wideband couplers

<i>Ordering Information:</i>	
	800 Village Walk #316
	Guilford, CT 06437
	Ph: 203-401-8093
	Email orders to: <a href="mailto:sales@xsoptix.com">sales@xsoptix.com</a>
	Fax orders to: 800-878-7282

For further information

E: [torquaysales@goochandhousego.com](mailto:torquaysales@goochandhousego.com)

[goochandhousego.com](http://goochandhousego.com)

POLARIZATION MAINTAINING 1550 NM FIBER COUPLED ACOUSTO-OPTIC MODULATOR