

PM Fiber-Q®

Polarization Maintaining 1060 nm Fiber Coupled Acousto-Optic Modulator

T-M150-0.4C2G-3-F2P

The Fiber-Q® acousto-optic modulator is designed for use in pulsed fiber laser amplifier systems. Giving optimum performance in demanding applications, such as material processing.

Gooch & Housego specialize in providing optical components for high power fiber laser and amplifier systems. In-house control of critical manufacturing processes; from crystalline material selection and orientation, cutting, polishing and anti-reflection coating through to fiber coupling, ensure our components are of the highest optical quality.

In addition to the standard product shown, custom configurations are available for specialized applications.



Key Features

- Low insertion loss
- Compact low profile package
- Rugged hermetic design
- Stable performance
- Custom configurations available

Applications

- Fiber laser
- Fiber amplifier
- Pulse picker

POLARIZATION MAINTAINING 1060 NM FIBER COUPLED ACOUSTO-OPTIC MODULATOR

General Specifications

Parameter	Min	Max	Typical	Comments
Interaction material	-	-	-	Tellurium Dioxide
Wavelength	1030 nm	1090 nm	1060 nm	Other wavelengths available on request
Average optical power handling	-	5 W	-	
Peak optical power handling	-	30 kW	-	Dependent on pulse width
Insertion loss	-	2.5 dB	2 dB	
Polarization extinction ratio	18 dB	-	20 dB	
Extinction ratio	50 dB	-	-	
Return loss (RF ON/RF OFF)	40 dB	-	-	
Rise-time/fall-time: (10% - 90%)	-	30 ns	-	
Frequency	-	-	150 MHz	
VSWR	-	1.2:1	-	
Input impedance	-	-	50 Ω	
RF power	-	2 W	-	Absolute maximum rating. Higher power will cause damage.
Frequency shift	-	-	150 MHz	Upshift
Fiber type	-	-	-	Fujikura PM980 (SM98-PS-U25A) or equivalent
Fiber length	1.5 m	-	-	900 μ m PVDF sleeving
Fiber termination	-	-	-	Bare fiber

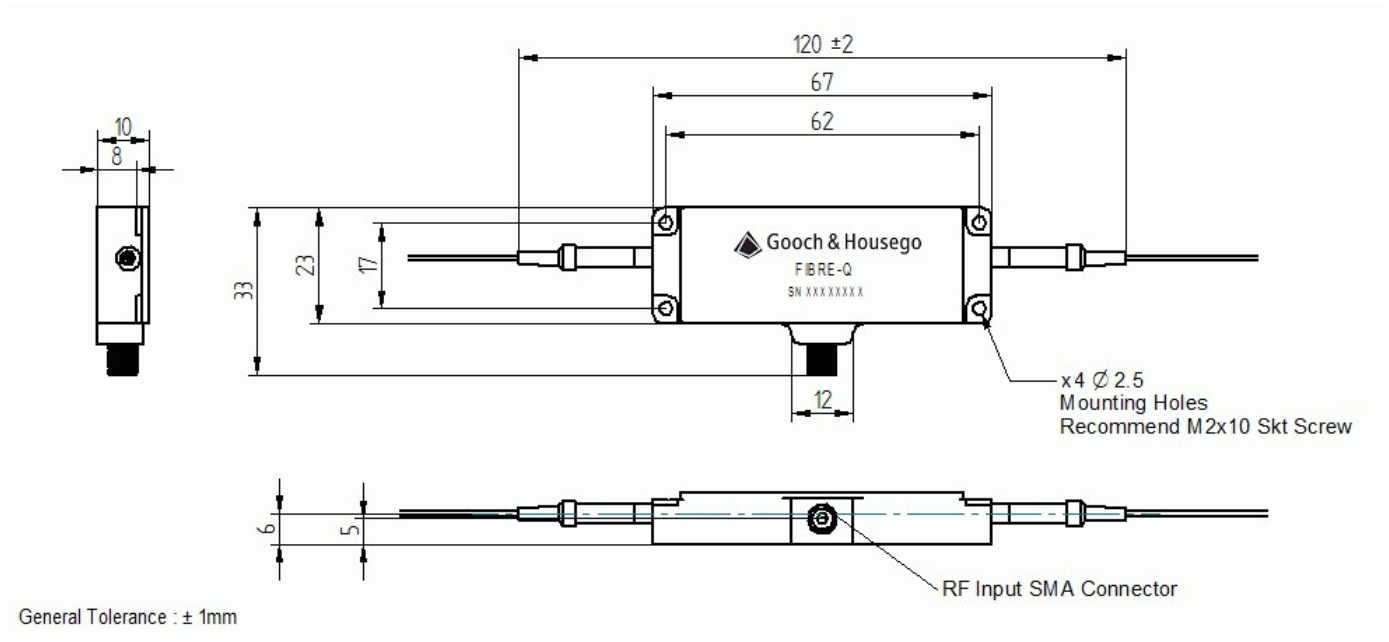

Other products which may be of interest

- HI REL couplers
- High power multimode combiners
- Combiners with all types of signal feedthrough fiber
- Ultra-low ratio tap couplers
- WDMs for combining signals with red pointer lasers
- OCT wideband couplers

<p>Ordering Information:</p>  <p>Email orders to: sales@xsoptix.com Fax orders to: 800-878-7282</p>	<p>800 Village Walk #316 Guilford, CT 06437 Ph: 203-401-8093</p>
---------------------------------------------------------------------------------------------------------------------------------------------------------------------------------------------------------------------------------------------------	--------------------------------------------------------------------------------------------

For further information

E: torquaysales@goochandhousego.com

goochandhousego.com

POLARIZATION MAINTAINING 1060 NM FIBER COUPLED ACOUSTO-OPTIC MODULATOR