



DUAL AXES MAGNETIC MIRRORS

OVERVIEW

The **sercalo** magnetic deflection units are used for optical beam steering and scanning. The 2-D mirror has a reflective surface of 2.5 x 3.6 mm.

Using magnetic actuation, the deflection angle is set linearly with the driving current. The mirror is designed for DC operation as well as scanning.

FEATURES

- 2 actuation Axes
- $\pm 4^\circ$ (up to 5°)
- Linear control

APPLICATIONS

- 2D Static and dynamic Optical Beam Steering
- 2D Optical Scanner Device

ORDERING INFORMATION

- MM-2536-2-AU** 2.5x3.6mm Gold surface finish
MM-2536-2-AL 2.5x3.6mm Aluminum surface finish

CONTACT

Sercalo Microtechnology Ltd
Landstrasse 151, FL 9494 Schaan
Principality of Liechtenstein
Tel. +423 237 57 97 Fax. +423 237 57 48
www.sercalo.com Email: info@sercalo.com

Ordering Information:



800 Village Walk #316
Guilford, CT 06437
Ph: 203-401-8093

Email orders to: sales@xsoptix.com
Fax orders to: 800-878-7282

TECHNICAL SPECIFICATIONS

	Unit	Min	Typ	Max
Max actuation Current	<i>mA</i>			200
Max actuation Power	<i>W</i>			1
Surface finish	-		Gold or Aluminium	
Reflectivity (800-2000 nm)	%	95		
Mirror Size (A x B)	<i>mm</i> ²		2.5 x 3.6	
Mirror Flatness (ROC)	<i>m</i>	10		
Tilt Angle DC (mechanical)	<i>deg</i>	± 4°		(up to 5°)
Resonance Frequency X	<i>Hz</i>	350	390	
Resonance Frequency Y	<i>Hz</i>	200	240	
Angle of Incidence	<i>deg</i>			45
Operating Temperature	°C	-5		85
Storage Temperature	°C	-40		85

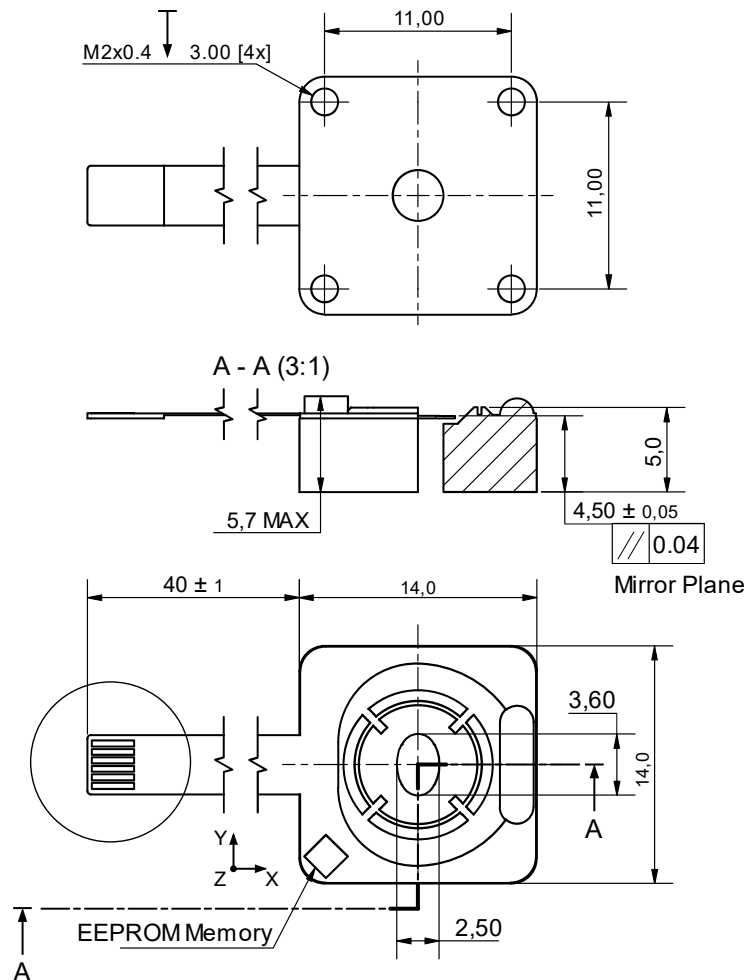

Figure 1: Mechanical layout for MM2536-2 Deflection Unit (units = mm)