



FEATURES

- High speed scrambling
- Low insertion loss
- Very low Scrambling voltage
- PMD mitigation
- Compact design

APPLICATIONS

- Combat PHB in the EDFA
- Optical communication networks
- Fiber sensor systems
- High-speed test equipment

OPTIONS

- Other modulation frequencies
- Custom design
- Chip on sub-mount

MATCHING COMPONENT

- ixblue RF drivers

The PSC-LN are a compact and high speed electro-optic Polarization Scramblers. These integrated-optic devices feature a low-loss single-mode waveguide and are capable of modulating the polarization at frequencies ranging from DC to more than 10 GHz. They operate over a broad optical bandwidth of more than 100 nm. These devices are based on a simple TE-TM phase retarders which are capable of depolarizing light in a fixed, well maintained polarization state with a residual degree of polarization.

The PSC-LN Polarization Scrambler is based on a birefringent LiNbO_3 phase modulator whose waveguide is illuminated at 45° of its main axis. The input state of polarization (SOP) is thus split up in two orthogonal TE and TM polarization states. The differential TE-TM phase shift is then generated here via the linear electro-optic effect by applying simple sinusoidal or saw-tooth voltages.

Low Bandwidth Polarization Scrambler - Highlights

Parameter	PSC-LN-0.1
Operating wavelength	1530 nm - 1625 nm
Electro-optical bandwidth	150 MHz
TE-TM Halfwave voltage	6 V
Insertion loss	3.5 dB

Specifications given at 25 °C, 1550 nm.

Wide Bandwidth Polarization Scrambler - Highlights

Parameter	PSC-LN-10
Operating wavelength	1530 nm - 1625 nm
Electro-optical bandwidth	12 GHz
TE-TM Halfwave voltage	6 V
Insertion loss	2.5 dB

Specifications given at 25 °C, 1550 nm.

Ordering Information:



800 Village Walk #316
Guilford, CT 06437
Ph: 203-401-8093

Email orders to: sales@xsoptix.com
Fax orders to: 800-878-7282

PSC-LN-0.1

150 MHz Polarization Scrambler

Electrical Characteristics

Parameter	Symbol	Condition	Min	Typ	Max	Unit
Electro-optic bandwidth	S_{21}	-	150	200	-	MHz
TE-TM Halfwave voltage	$V_{\pi} RF_{50\text{ kHz}}$	1xV π RF @50 kHz	-	6	7	V
RF input impedance	Z_{in-RF}	-	-	10 000	-	Ω

Optical Characteristics

Parameter	Symbol	Condition	Min	Typ	Max	Unit
Crystal	-	-	Lithium Niobate X-Cut Y-Prop			
Waveguide process	-	-	Ti diffusion			
Operating wavelength	λ	-	1530	1550	1625	nm
Insertion loss	IL	Without optical connectors	-	3.5	4	dB
Polarization dependent loss	PDL	-	-	-	1	dB
Optical return loss	ORL	-	-40	-45	-	dB

All specifications given at 25 °C, 1550 nm, unless differently specified.

Absolute Maximum Ratings

Stresses in excess of the absolute maximum ratings can cause permanent damage to the device. These are absolute stress ratings only. Functional operation of the device is not implied at these or any other conditions in excess of those given in the operational sections of the data sheet. Exposure to absolute maximum ratings for extended periods can adversely affect device reliability.

Parameter	Symbol	Min	Max	Unit
Modulation voltage range	EV_{in}	-20	20	V
Optical input power	OP_{in}	-	20	dBm
Operating temperature	OT	0	+70	°C
Storage temperature	ST	-40	+85	°C

PSC-LN-10

10 GHz Polarization SCrambler

Electrical Characteristics

Parameter	Symbol	Condition	Min	Typ	Max	Unit
Electro-optic bandwidth	S_{21}	From 2 GHz	10	12	-	GHz
Ripple S_{21}	ΔS_{21}	-	-	0.5	1	dB
Electrical return loss	S_{11}	-	-	-17	-14	dB
TE-TM Halfwave voltage	V_{π} RF	1xV π RF @50 kHz	-	6	7	V
Impedance matching	Z_{in-RF}	-	-	50	-	Ω

Optical Characteristics

Parameter	Symbol	Condition	Min	Typ	Max	Unit
Crystal	-	-	Lithium Niobate Z-Cut Y-Prop			
Waveguide process	-	-	Ti diffusion			
Operating wavelength	λ	-	1530	1550	1625	nm
Insertion loss	IL	Without optical connectors	-	2.5	3.5	dB
Optical return loss	ORL	-	-40	-45	-	dB

All specifications given at 25 °C, 1550 nm, unless differently specified.

Absolute Maximum Ratings

Stresses in excess of the absolute maximum ratings can cause permanent damage to the device. These are absolute stress ratings only. Functional operation of the device is not implied at these or any other conditions in excess of those given in the operational sections of the data sheet. Exposure to absolute maximum ratings for extended periods can adversely affect device reliability.

Parameter	Symbol	Min	Max	Unit
RF input power	EP_{in}	-	28	dBm
Optical input power	OP_{in}	-	20	dBm
Operating temperature	OT	0	+70	°C
Storage temperature	ST	-40	+85	°C

Mechanical Diagram and pinout

All measurements in mm

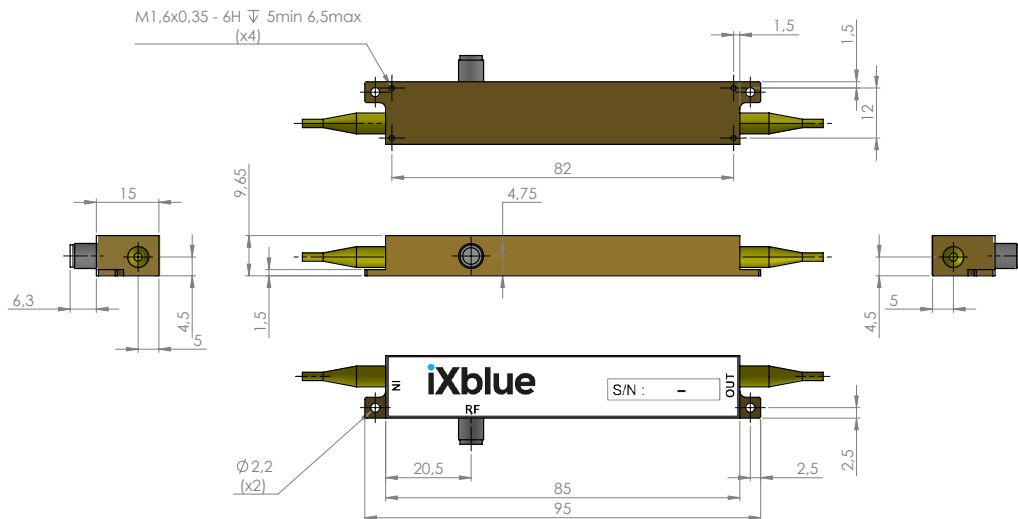

Port	Function	Note
IN	Optical input port	Polarization maintaining 1550 nm Corning PM 15-U25D length: 1.5 meter, buffer diameter: 900 mm
OUT	Optical output port	Single mode fiber SMF 28, length: 1.5 meter, buffer diameter: 900 mm
RF	RF input port	Wiltron female K (SMA compatible)

Ordering information

PSC-LN-X-Y-Z-AB-CD

- X = Bandwidth: 0.1 150 MHz 10 10 GHz
- Y = Input fiber : P Polarization maintaining
- Z = Output fiber : S Standard single mode
- AB = Input connector : 00 bare fiber FA FC/APC FC FC/UPC
- CD = Output connector : 00 bare fiber FA FC/APC FC FC/UPC
- Note : optical connectors are Senko with narrow key or equivalent

About us

ixBlue Photonics produces specialty optical fibers and Bragg gratings based fiber optics components and provides optical modulation solutions based on the company lithium niobate (LiNbO₃) modulators and RF electronic modules.

ixBlue Photonics serves a wide range of industries: sensing and instruments, defense, telecommunications, space and fiber lasers as well as research laboratories all over the world.

3, rue Sophie Germain
25 000 Besançon - FRANCE
Tel. : +33 (0) 381 853 180 - Fax : + 33 (0) 381 811 557

ixblue reserves the right to change, at any time and without notice, the specifications, design, function or form of its products described herein. All statements, specification, technical information related to the products herein are given in good faith and based upon information believed to be reliable and accurate at the moment of printing. However the accuracy and completeness thereof is not guaranteed. No liability is assumed for any inaccuracies and as a result of use of the products. The user must validate all parameters for each application before use and he assumes all risks in connection with the use of the products