



FEATURES

- High optical power handling
- High Bandwidth (> 10 GHz)
- High stability
- Low V_{π}
- Low insertion loss

APPLICATIONS

- Interferometric based sensors
- Quantum optics
- Frequency shifting
- Pound-Drever-Hall locking

OPTIONS

- Hermetic sealing
- 20 GHz version
- 850 nm and 1060 nm versions

RELATED EQUIPMENTS

- RF amplifiers
- NIR-MX950-LN intensity modulators

The NIR-MPX950 series are phase modulators especially designed to operate in the 950 nm wavelength band. They are available with various modulation bandwidth, from low frequency to 20 GHz and beyond.

Like all ixblue Near InfraRed (NIR) modulators, the NIR-MPX950 series use a proton exchanged based waveguide process that confers them an unparalleled stability and a high photo-refractive threshold.

NIR-MPX950-LN-0.1 series Performance Highlights

Parameter	Min	Typ	Max	Unit
Operating wavelength	850	900	950	nm
Electro-optical bandwidth	100	150	-	MHz
V_{π} RF @50 kHz	-	2.2	3.2	V
Insertion loss	-	3.5	5.5	dB

Specifications given at 25 °C, 950 nm.

NIR-MPX950-LN-05 series Performance Highlights

Parameter	Min	Typ	Max	Unit
Operating wavelength	850	900	950	nm
Electro-optical bandwidth	5	-	-	GHz
V_{π} RF @50 kHz	-	3.5	4.5	V
Insertion loss	-	3.5	4.5	dB

Specifications given at 25 °C, 950 nm.

NIR-MPX950-LN-10 series Performance Highlights

Parameter	Min	Typ	Max	Unit
Operating wavelength	850	900	950	nm
Electro-optical bandwidth	10	12	-	GHz
V_{π} RF @50 kHz	-	4.5	5.5	V
Insertion loss	-	3.5	5.5	dB

Specifications given at 25 °C, 950 nm.

Ordering Information:



800 Village Walk #316
Guilford, CT 06437
Ph: 203-401-8093

Email orders to: sales@xsoptix.com
Fax orders to: 800-878-7282

NIR-MPX950-LN-0.1 150 MHz Phase Modulator

Electrical Characteristics

Parameter	Symbol	Condition	Min	Typ	Max	Unit
Electro-optic bandwidth @-3 dB	S_{21}	RF electrodes	100	150	-	MHz
$V\pi$ RF @50 kHz	$V\pi$ RF _{50 kHz}	RF electrodes	-	2.2	3.2	V
RF input impedance	Z_{in-RF}	-	-	10 000	-	Ω

Optical Characteristics

Parameter	Symbol	Condition	Min	Typ	Max	Unit
Crystal	-	-	Lithium Niobate X-Cut Y-Prop, MgO doped			
Waveguide process	-	-	Proton exchange			
Operating wavelength	λ	-	850	900	950	nm
Insertion loss	IL	Without optical connectors	-	3.5	5.5	dB
Optical return loss	ORL	-	-40	-45	-	dB

All specifications given at 25 °C, 944 nm, unless differently specified.

Absolute Maximum Ratings

Stresses in excess of the absolute maximum ratings can cause permanent damage to the device. These are absolute stress ratings only. Functional operation of the device is not implied at these or any other conditions in excess of those given in the operational sections of the data sheet. Exposure to absolute maximum ratings for extended periods can adversely affect device reliability.

Parameter	Symbol	Min	Max	Unit
Modulation voltage range	$E_{V_{in}}$	-20	20	V
Optical input power (CW mode)	OP_{in}	-	+14	dBm
Operating temperature	OT	0	+70	°C
Storage temperature	ST	-40	+85	°C

NIR-MPX950-LN-05

5 GHz Phase modulator

Electrical Characteristics

Parameter	Symbol	Condition	Min	Typ	Max	Unit
Electro-optic bandwidth	S_{21}	RF electrodes, from 2 GHz	5	-	-	GHz
Ripple S_{21}	ΔS_{21}	RF electrodes	-	0.5	1	dB
Electrical return loss	S_{11}	RF electrodes	-	-12	-10	dB
V_{π} RF @50 kHz	$V_{\pi RF_{50\text{ kHz}}}$	RF electrodes	-	3.5	4.5	V
RF input impedance	Z_{in-RF}	-	-	50	-	Ω

Optical Characteristics

Parameter	Symbol	Condition	Min	Typ	Max	Unit
Crystal	-	-	Lithium Niobate X-Cut Y-Prop, MgO doped			
Waveguide process	-	-	Proton exchange			
Operating wavelength	λ	-	850	900	950	nm
Insertion loss	IL	Without optical connectors	-	3.5	5.5	dB
Optical return loss	ORL	-	-40	-45	-	dB

All specifications given at 25 °C, 944 nm, unless differently specified.

Absolute Maximum Ratings

Stresses in excess of the absolute maximum ratings can cause permanent damage to the device. These are absolute stress ratings only. Functional operation of the device is not implied at these or any other conditions in excess of those given in the operational sections of the data sheet. Exposure to absolute maximum ratings for extended periods can adversely affect device reliability.

Parameter	Symbol	Min	Max	Unit
RF input power (CW mode)	EP_{in}	-	+28	dBm
Optical input power (CW mode)	OP_{in}	-	+14	dBm
Operating temperature	OT	0	+70	°C
Storage temperature	ST	-40	+85	°C

NIR-MPX950-LN-10

10 GHz Phase modulator

Electrical Characteristics

Parameter	Symbol	Condition	Min	Typ	Max	Unit
Electro-optic bandwidth	S_{21}	RF electrodes, from 2 GHz	10	12	-	GHz
Ripple S_{21}	ΔS_{21}	RF electrodes	-	0.5	1	dB
Electrical return loss	S_{11}	RF electrodes	-	-12	-10	dB
V_{π} RF @50 kHz	V_{π} RF _{50 kHz}	RF electrodes	-	4.5	5.5	V
RF input impedance	Z_{in-RF}	-	-	50	-	Ω

Optical Characteristics

Parameter	Symbol	Condition	Min	Typ	Max	Unit
Crystal	-	-	Lithium Niobate X-Cut Y-Prop, MgO doped			
Waveguide process	-	-	Proton exchange			
Operating wavelength	λ	-	850	900	950	nm
Insertion loss	IL	Without connectors	-	3.5	5.5	dB
Optical return loss	ORL	-	-40	-45	-	dB

All specifications given at 25 °C, 944 nm, unless differently specified.

Absolute Maximum Ratings

Stresses in excess of the absolute maximum ratings can cause permanent damage to the device. These are absolute stress ratings only. Functional operation of the device is not implied at these or any other conditions in excess of those given in the operational sections of the data sheet. Exposure to absolute maximum ratings for extended periods can adversely affect device reliability.

Parameter	Symbol	Min	Max	Unit
RF input power (CW mode)	EP_{in}	-	+28	dBm
Optical input power (CW mode)	OP_{in}	-	+14	dBm
Operating temperature	OT	0	+70	°C
Storage temperature	ST	-40	+85	°C

Mechanical Diagram and Pinout

All measurements in mm

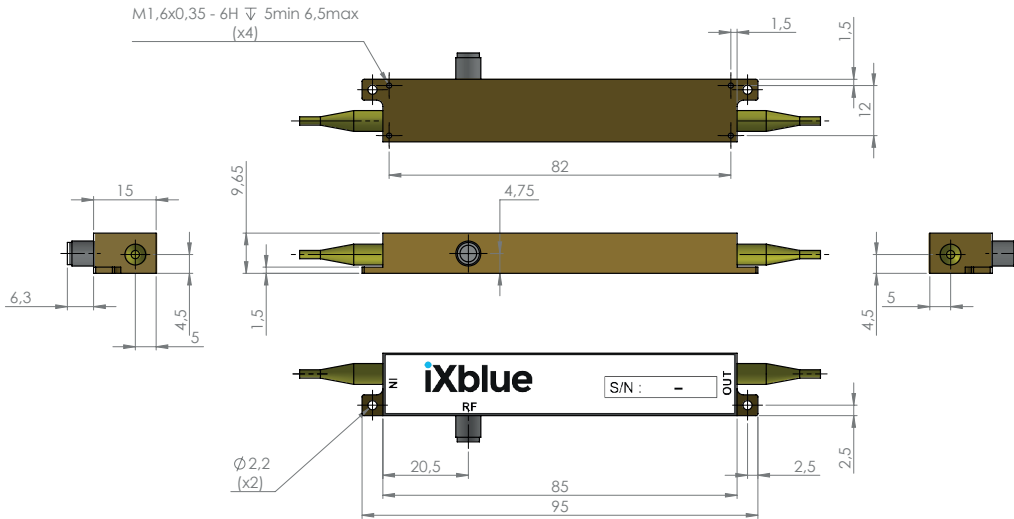

Port	Function	Note
IN	Optical input port	Polarization maintaining 800 nm Corning 85-U25D length : 1.5 meter, buffer diameter : 900 um
OUT	Optical output port	Polarization maintaining 800nm Corning 85-U25D length : 1.5 meter, buffer diameter : 900 um
RF	RF input port	Wiltron female K

Ordering information

NIR-MPX950-LN-XX-Y-Z-AB-CD

XX = Bandwidth : 0.1 150 MHz 05 5 GHz 10 10 GHz 20 20 GHz
 Y = Input fiber : P Polarisation maintaining S Standard single mode
 Z = Input fiber : P Polarisation maintaining S Standard single mode
 AB = Output connector : 00 bare fiber FA FC/APC FC FC/SPC
 CD = Output connector : 00 bare fiber FA FC/APC FC FC/SPC

About us

ixBlue Photonics produces specialty optical fibers and Bragg gratings based fiber optics components and provides optical modulation solutions based on the company lithium niobate (LiNbO₃) modulators and RF electronic modules.

ixBlue Photonics serves a wide range of industries: sensing and instruments, defense, telecommunications, space and fiber lasers as well as research laboratories all over the world.