



The ModBox-IQ is a high performance modulation unit that allows telecommunication engineers and research scientists to produce optical signals with complex modulation schemes (QPSK, QAM, OFDM). The ModBox-IQ is easy to use and finds its place in production test beds, development laboratories and scientific setups.

The high bandwidth and low harmonic distortion of the ModBox-IQ allow to generate particularly clean QAM and OFDM optical signals thanks to the high linearity of its internal components.

The ModBox-IQ integrates a high bandwidth dual Mach-Zehnder modulator and high speed RF drivers capable of dealing with data rates up to 32 Gbaud. It features an embedded control electronics that allows to set the modulator operating point in various positions so as to multiply the test scenarios.

FEATURES

- Data-rate up to 32 Gbaud/s
- Low EVM
- High SNR
- Automatic / Manual control

APPLICATIONS

- Transmission system test
- Components characterization
- R&D Datacom/Telecom
- Telecom laboratories

OPTIONS

- Dual Polarization
- C, L, O bands operation
- Multi-Channel
- DFB and tunable lasers

Performance Highlights

Parameter	Min	Typ	Max
Operating wavelength	C-band, L band		
Modulation format	QPSK, QAM, OFDM		
Data-rate (QPSK, QAM)	1 Gbaud/s	-	32 Gbauds/s
Insertion loss	-	-	10 dB

Ordering Information:



800 Village Walk #316
Guilford, CT 06437
Ph: 203-401-8093

Email orders to: sales@xsoptix.com
Fax orders to: 800-878-7282

Functional Block Diagram

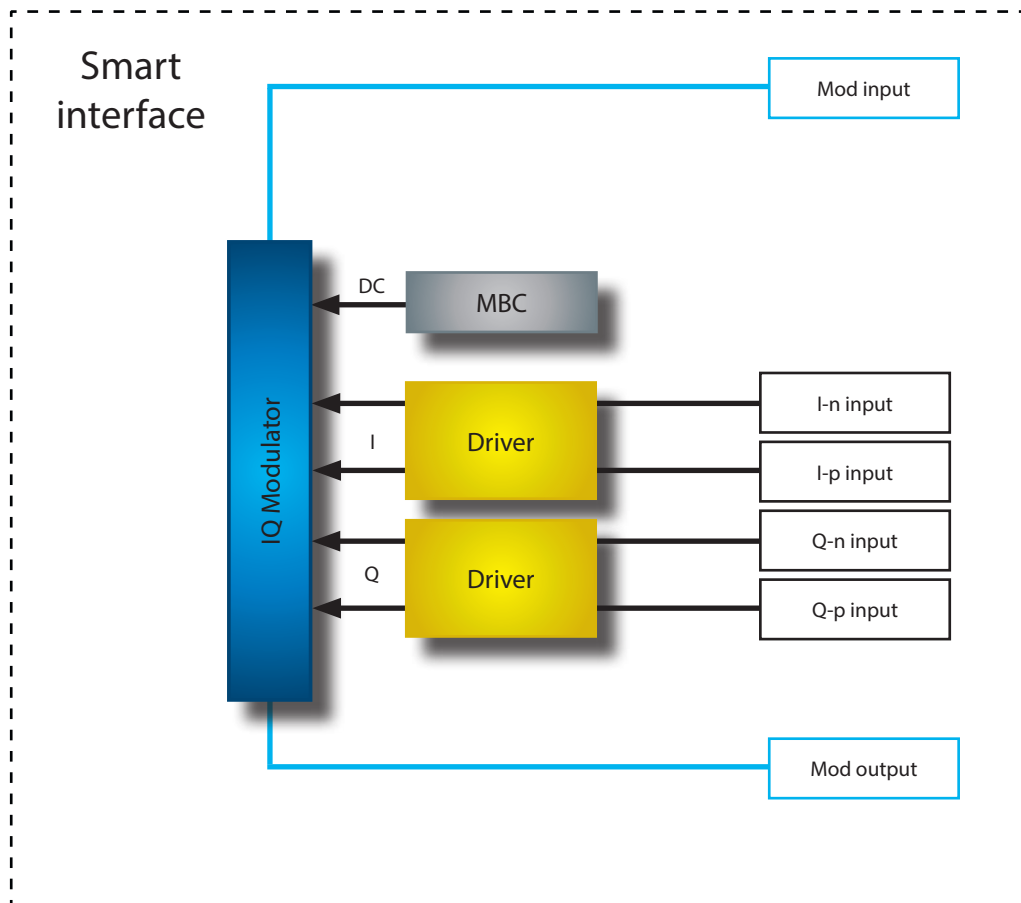

The ModBox-IQ Smart Interface allows to control all modulation parameters with just a simple keypad and rotary knob, making the ModBox-IQ a user friendly coherent multilevel transmitter.

The ModBox IQ also offers a simple software solution that allows to control all setting parameters at a glance thanks to a virtual instrument interface. The software interface is easily accessible from a PC through the USB port.

Optical Input Specifications User supplied, not a ModBox specification

Parameter	Symbol	Condition	Min	Typ	Max	Unit
Data Input Specifications						
Source type	-	CW	DFB, tunable laser			
Wavelength	λ	C-band, L-band	1527	1550	1608	nm
Input power	P_{CW}	CW	1	-	20	mW
Polarization	P	-	Linear and controlled			

Electrical Input Specifications User supplied, not a ModBox specification

Parameter	Symbol	Condition	Min	Typ	Max	Unit
Input electrical termination	-	I-n, I-p, Q-n, Q-p	Differential			-
QPSK modulation scheme						
Modulation Format	-	I-n, I-p, Q-n, Q-p	NRZ			-
Data-rate	-	I-n, I-p, Q-n, Q-p	-	-	32	Gbaud/s
Input signal amplitude	V_{IN}	50 Ω	-	450	-	mVpp
QAM modulation scheme						
Modulation Format	-	I-n, I-p, Q-n, Q-p	Multi-level			-
Input signal amplitude	V_{IN}	50 Ω	-	250	-	mVpp

Optical Output Specifications

Parameter	Symbol	Condition	Min	Typ	Max	Unit
Data-rate	-	QPSK, QAM	1	-	32	Gbaud/s
Insertion loss	IL	At maximum transmission	-	7	10	dB
Chirp	α	-	-0.1	0	0.1	-
Optical return loss	ORL	-	-45	-50	-	dB
Static extinction ratio	ER	-	20	25	-	dB
RF gain adjustment	ΔG	Smart	-	3	-	dB
Bias Control	MBC	Smart	Automatic / Manual			-

Absolute Maximum Ratings

Stresses in excess of the absolute maximum ratings can cause permanent damage to the device. These are absolute stress ratings only. Functional operation of the device is not implied at these or any other conditions in excess of those given in the operational sections of the data sheet. Exposure to absolute maximum ratings for extended periods can adversely affect device reliability.

Parameter	Symbol	Min	Max	Unit
RF input power	EP_{in}	-	-2	dBm
Optical input power	OP_{in}	-	13	dBm

The ModBox can integrate up to 4 DFB or tunable lasers. The ModBox Smart Interface allows the user to control laser power and wavelength. In case of several DFB lasers, the ModBox is optimised for each individual wavelength.

Optional C-L Band DFB Laser Specifications

Parameter	Symbol	Condition	Min	Typ	Max	Unit
Wavelength	λ	Other wavelength on request	1550.12 nm - ITU CH 34 *			-
Laser type	-	-	DFB			-
Optical output power	-	CW	-	20*	-	mW
Spectrum linewidth	$\Delta\lambda$	FWHM	-	-	1	MHz
Optical return loss	ORL	-	30	35	-	dB
Side mode suppression ratio	SMSR	-	30	-	-	dB
Optical output power adjustment	P_{CW}	Front panel & GUI	0	-	20	mW
Wavelength laser tuning range	-	Front panel & GUI	-	0.8	1	nm

* Other ITU-Channel on request.

Optional C-Band & L-Band Tunable Laser Specifications

Parameter	Symbol	Condition	Min	Typ	Max	Unit
Optical wavelength range	λ	C-band version	1527.60	-	1565.50	nm
Optical wavelength range	λ	L-band version	1570.01	-	1608.76	nm
Optical output power	P_{CW}	CW	-	20	-	mW
Frequency fine tune resolution	FTF	-	-	1	-	MHz
Optical output power accuracy	P_{CW-acc}	-	-1	-	1	dB
Wavelength accuracy	$\Delta\lambda_{acc}$	-	-1.5	-	1.5	GHz
Spectrum linewidth	$\Delta\lambda$	FWHM @-3 dB, instantaneous	-	-	100	kHz
Side Mode Suppression Ratio	SMSR	-	40	55	-	dB
RIN	RIN_7	For 7 dBm output power	-	-	-140	dB/Hz
	RIN_{13}	For 13 dBm output power	-	-	-145	
Optical output power adjustment	ΔP_{CW}	Front panel & GUI	5	-	20	mW

Eye Diagrams

The following equipment was used in obtaining these results :

- Pulse Pattern Generator : Anritsu MP1800A
- Oscilloscope Agilent 86100B with time base precision module 86107A

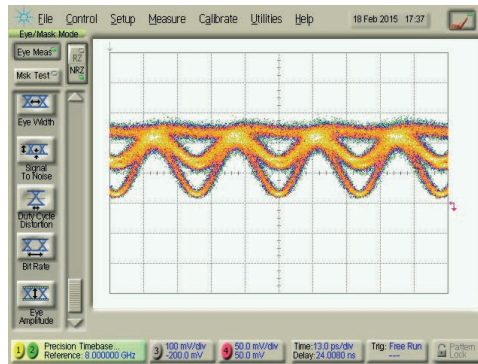

QPSK - 32 Gbaud/s

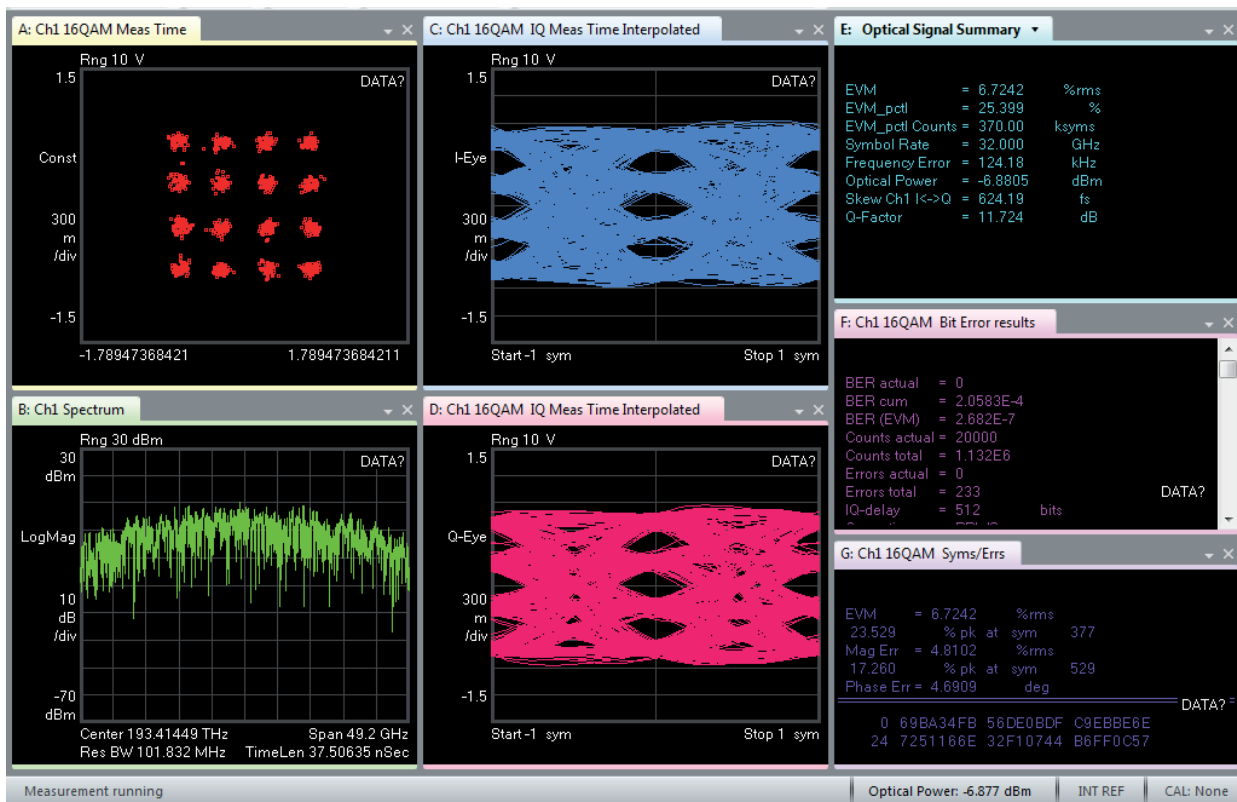

16QAM- 32 Gbaud/s

Front Panel

Parameter	
Power	Powers the system and lits green when the switch is set on
LCD	Displays ModBox current status and allows the user to edit parameter in the ModBox menus
Keypad	Allows one to browse through the smart interface menus and edit the system's parameters
System rotary knob	Allows browsing and editing through the ModBox menus
Mod In / Mod Out	Laser modulation input and output ports - Cable gland with FC/APC fiber connector
I Channel differential RF input	Differential 2.92 mm RF connector (In: I negative, Ip: I positive)
Q Channel differential RF input	Differential 2.92 mm RF connector (Qn: Q negative, Qp: Q positive)



Non contractual picture

There are monitoring LEDs on the front panel upper right corner:

- Driver I & Driver Q green LEDs monitor RF driver operation (they lit green when the corresponding driver is powered),
- MBCx with x= 1, 2, 3 are modulator controller power status LEDs (green light means that the corresponding controller is "powered").

Ordering Information

ModBox-IQ-OL-DR-XX

OL = Laser Option, omit if no laser - CHX* : CW ITU Channel - C or L Tunable laser : C-Tun or L-Tun

DR = maximum output Data-Rate : 10Gbaud/s, 32Gbaud/s

XX = Input / Output connectors, FA : FC/APC - FC : FC/UPC - SC : SC/UPC

Example: ModBox-IQ-CH34-32Gbaud/s-FA is a modulation unit embedding a 1550.12 nm CW laser, operating up to 32Gbaud/s QPSK & QAM and coming with FC-APC connectors.

About us

ixBlue Photonics includes ixBlue ixFiber brand that produces specialty optical fibers and Bragg gratings based fiber optics components and ixBlue Photline brand that provides optical modulation solutions based on the company lithium niobate (LiNbO₃) modulators and RF electronic modules.

ixBlue Photonics serves a wide range of industries : sensing and instruments, defense, telecommunications, space and fiber lasers as well as research laboratories all over the world.

ZI Les Tilleroyes - Trépillot
16, rue Auguste Jouchoux - 25000 Besançon - FRANCE
tél. : +33 (0) 381 853 180 - fax : + 33 (0) 381 811 557

ixBlue reserves the right to change, at any time and without notice, the specifications, design, function or form of its products described herein. All statements, specification, technical information related to the products herein are given in good faith and based upon information believed to be reliable and accurate at the moment of printing. However the accuracy and completeness thereof is not guaranteed. No liability is assumed for any inaccuracies and as a result of use of the products. The user must validate all parameters for each application before use and he assumes all risks in connection with the use of the products.