

### FEATURES

- High Bandwidth
- C & L bands
- Low insertion loss
- Low  $V_{\pi}$

### APPLICATIONS

- Side bands generation
- Interferometric sensing
- Frequency shifting / broadening
- Quantum key distribution
- High data rate telecommunications

### OPTIONS

- 1310 nm versions
- 800 nm, 1000 nm, 2.0  $\mu\text{m}$  versions
- Low residual intensity modulation

### RELATED EQUIPMENTS

- Matched RF amplifiers

The MPX-LN and MPZ-LN series make up the most comprehensive range of electro-optic phase modulators available on the market for the 1550 nm wavelength band.

- The MPZ-LN series are ideally suited for high bandwidth operation at 1GHz, 10 GHz, 20 GHz and up to 40 GHz.
- The MPX-LN-0.1 has a high impedance input optimized for modulation frequencies below 150 MHz.

Designed using state-of-the-art and proven lithium niobate technology, MPX-LN and MPZ-LN phase modulators are easy to operate and to integrate. They offer the highest performance for a wide range of applications from laboratory experiments to demanding industrial systems.

### Low and Medium Bandwidth Phase Modulators - Highlights

Parameter	MPX-LN-0.1	MPZ-LN-01
Operating wavelength	1530 nm - 1625 nm	
Electro-optical bandwidth	150 MHz	1.5 GHz
$V_{\pi}$ RF @50 kHz	3.5 V	3 V
Insertion loss	2.7 dB	2.5 dB

Specifications given at 25 °C, 1550 nm.

### Wide Bandwidth Phase Modulators - Highlights

Parameter	MPZ-LN-10	MPZ-LN-20	MPZ-LN-40
Operating wavelength	1530 nm - 1625 nm		
Electro-optical bandwidth	12 GHz	25 GHz	33 GHz
$V_{\pi}$ RF @50 kHz	4 V	6 V	6 V
Insertion loss	2.5 dB	2.5 dB	2.5 dB

Specifications given at 25 °C, 1550 nm.

#### Ordering Information:



800 Village Walk #316  
Guilford, CT 06437  
Ph: 203-401-8093

Email orders to: [sales@xsoptix.com](mailto:sales@xsoptix.com)  
Fax orders to: 800-878-7282

## MPX-LN-0.1

### 150 MHz Phase Modulator

#### Electrical Characteristics

Parameter	Symbol	Condition	Min	Typ	Max	Unit
Electro-optic bandwidth	$S_{21}$	RF electrodes	-	150	-	MHz
$V_{\pi}$ RF @50 kHz	$V_{\pi}$ RF <sub>50 kHz</sub>	RF electrodes	-	3.5	4	V
RF input impedance	$Z_{in-RF}$	-	-	10 000	-	$\Omega$

#### Optical Characteristics

Parameter	Symbol	Condition	Min	Typ	Max	Unit
Crystal	-	-	Lithium Niobate X-Cut Y-Prop			
Waveguide process	-	-	Ti diffusion			
Operating wavelength	$\lambda$	-	1530	1550	1625	nm
Insertion loss	IL	Without connectors	-	2.7	3.5	dB
Polarization dependent loss	PDL	-	-	5	8	dB
Optical return loss	ORL	-	-40	-45	-	dB

All specifications given at 25 °C, 1550 nm, unless differently specified.

#### Absolute Maximum Ratings

Stresses in excess of the absolute maximum ratings can cause permanent damage to the device. These are absolute stress ratings only. Functional operation of the device is not implied at these or any other conditions in excess of those given in the operational sections of the data sheet. Exposure to absolute maximum ratings for extended periods can adversely affect device reliability.

Parameter	Symbol	Min	Max	Unit
Modulation voltage range	$EV_{in}$	-20	20	V
Optical input power	$OP_{in}$	-	20	dBm
Operating temperature	OT	0	+70	°C
Storage temperature	ST	-40	+85	°C

## MPZ-LN-01 1 GHz Phase Modulator

### Electrical Characteristics

Parameter	Symbol	Condition	Min	Typ	Max	Unit
Electro-optic bandwidth	$S_{21}$	-	1	1.5	-	GHz
Ripple $S_{21}$	$\Delta S_{21}$	RF electrodes	-	0.5	-	dB
Electrical return loss	$S_{11}$	RF electrodes	-	-15	-12	dB
$V_{\pi}$ RF @ 50 kHz	$V_{\pi RF_{50\text{ kHz}}}$	RF electrodes, @1550 nm	-	3	3.5	V
$V_{\pi}$ RF @ 1 GHz	$V_{\pi RF_{10\text{ GHz}}}$	RF electrodes, @1550 nm	-	3.1	3.6	V
Impedance matching	$Z_{in-RF}$	-	-	50	-	$\Omega$

### Optical Characteristics

Parameter	Symbol	Condition	Min	Typ	Max	Unit
Crystal	-	-	Lithium Niobate Z-Cut, X-Prop			
Waveguide process	-	-	Ti diffusion			
Operating wavelength	$\lambda$	-	1530	1550	1570	nm
Insertion loss	IL	Without connectors	-	2.5	3.5	dB
Optical return loss	ORL	-	-40	-45	-	dB

All specifications given at 25 °C, 1550 nm, unless differently specified.

### Absolute Maximum Ratings

Stresses in excess of the absolute maximum ratings can cause permanent damage to the device. These are absolute stress ratings only. Functional operation of the device is not implied at these or any other conditions in excess of those given in the operational sections of the data sheet. Exposure to absolute maximum ratings for extended periods can adversely affect device reliability.

Parameter	Symbol	Min	Max	Unit
RF input power	$EP_{in}$	-	33	dBm
Optical input power	$OP_{in}$	-	20	dBm
Operating temperature	OT	0	+70	°C
Storage temperature	ST	-40	+85	°C

## MPZ-LN-10

### 10 GHz Phase Modulator

#### Electrical Characteristics

Parameter	Symbol	Condition	Min	Typ	Max	Unit
Electro-optic bandwidth	$S_{21}$	RF electrodes, from 2 GHz	10	12	-	GHz
Ripple $S_{21}$	$\Delta S_{21}$	RF electrodes	-	0.5	1	dB
Electrical return loss	$S_{11}$	RF electrodes	-	-17	-14	dB
$V_{\pi}$ RF @ 50 kHz	$V_{\pi RF_{50\text{ kHz}}}$	RF electrodes, @ 1550 nm	-	4	5	V
$V_{\pi}$ RF @ 10 GHz	$V_{\pi RF_{10\text{ GHz}}}$	RF electrodes, @ 1550 nm	-	6	7	V
Impedance matching	$Z_{in-RF}$	-	-	50	-	$\Omega$

#### Optical Characteristics

Parameter	Symbol	Condition	Min	Typ	Max	Unit
Crystal	-	-	Lithium Niobate Z-Cut Y-Prop			
Waveguide process	-	-	Ti diffusion			
Operating wavelength	$\lambda$	-	1530	1550	1625	nm
Insertion loss	IL	Without connectors	-	2.5	3.5	dB
Optical return loss	ORL	-	-40	-45	-	dB

All specifications given at 25 °C, 1550 nm, unless differently specified.

#### Absolute Maximum Ratings

Stresses in excess of the absolute maximum ratings can cause permanent damage to the device. These are absolute stress ratings only. Functional operation of the device is not implied at these or any other conditions in excess of those given in the operational sections of the data sheet. Exposure to absolute maximum ratings for extended periods can adversely affect device reliability.

Parameter	Symbol	Min	Max	Unit
RF input power	$EP_{in}$	-	28	dBm
Optical input power	$OP_{in}$	-	20	dBm
Operating temperature	OT	0	+70	°C
Storage temperature	ST	-40	+85	°C

## MPZ-LN-20

20 GHz Phase Modulator

### Electrical Characteristics

Parameter	Symbol	Condition	Min	Typ	Max	Unit
Electro-optic bandwidth	$S_{21}$	RF electrodes, from 2 GHz	20	25	-	GHz
Ripple $S_{21}$	$\Delta S_{21}$	RF electrodes	-	0.5	1	dB
Electrical return loss	$S_{11}$	RF electrodes	-	-12	-10	dB
$V\pi$ RF @50 kHz	$V\pi$ RF <sub>50 kHz</sub>	RF electrodes, @1550 nm	-	6	7	V
$V\pi$ RF @20 GHz	$V\pi$ RF <sub>20 GHz</sub>	RF electrodes, @1550 nm	-	8	9	V
Impedance matching	$Z_{in-RF}$	-	-	50	-	$\Omega$

### Optical Characteristics

Parameter	Symbol	Condition	Min	Typ	Max	Unit
Crystal	-	-	Lithium Niobate Z-Cut Y-Prop			
Waveguide process	-	-	Ti diffusion			
Operating wavelength	$\lambda$	-	1530	1550	1625	nm
Insertion loss	IL	Without connectors	-	2.5	3	dB
Optical return loss	ORL	-	-40	-45	-	dB

All specifications given at 25 °C, 1550 nm, unless differently specified.

### Absolute Maximum Ratings

Stresses in excess of the absolute maximum ratings can cause permanent damage to the device. These are absolute stress ratings only. Functional operation of the device is not implied at these or any other conditions in excess of those given in the operational sections of the data sheet. Exposure to absolute maximum ratings for extended periods can adversely affect device reliability.

Parameter	Symbol	Min	Max	Unit
RF input power	EP <sub>in</sub>	-	28	dBm
Optical input power	OP <sub>in</sub>	-	20	dBm
Operating temperature	OT	0	+70	°C
Storage temperature	ST	-40	+85	°C

## MPZ-LN-40 40 GHz Phase Modulator

### Electrical Characteristics

Parameter	Symbol	Condition	Min	Typ	Max	Unit
Electro-optic bandwidth	$S_{21}$	RF electrodes, from 2 GHz	30	33	-	GHz
Ripple $S_{21}$	$\Delta S_{21}$	RF electrodes	-	0.5	1	dB
Electrical return loss	$S_{11}$	RF electrodes, 0 - 30 GHz	-	-12	-10	dB
$V_{\pi}$ RF @50 kHz	$V_{\pi}$ RF <sub>50 kHz</sub>	RF electrodes, @1550 nm	-	6	7	V
$V_{\pi}$ RF @30 GHz	$V_{\pi}$ RF <sub>30 GHz</sub>	RF electrodes, @1550 nm	-	8.5	10	V
Impedance matching	$Z_{in-RF}$	-	-	50	-	$\Omega$

### Optical Characteristics

Parameter	Symbol	Condition	Min	Typ	Max	Unit
Crystal	-	-	Lithium Niobate Z-Cut Y-Prop			
Waveguide process	-	-	Ti diffusion			
Operating wavelength	$\lambda$	-	1530	1550	1625	nm
Insertion loss	IL	Without connectors	-	2.5	3	dB
Optical return loss	ORL	-	-40	-45	-	dB

All specifications given at 25 °C, 1550 nm, unless differently specified.

### Absolute Maximum Ratings

Stresses in excess of the absolute maximum ratings can cause permanent damage to the device. These are absolute stress ratings only. Functional operation of the device is not implied at these or any other conditions in excess of those given in the operational sections of the data sheet. Exposure to absolute maximum ratings for extended periods can adversely affect device reliability.

Parameter	Symbol	Min	Max	Unit
RF input power	$EP_{in}$	-	28	dBm
Optical input power	$OP_{in}$	-	20	dBm
Operating temperature	OT	0	+70	°C
Storage temperature	ST	-40	+85	°C

Mechanical Diagram and Pinout

All measurements in mm

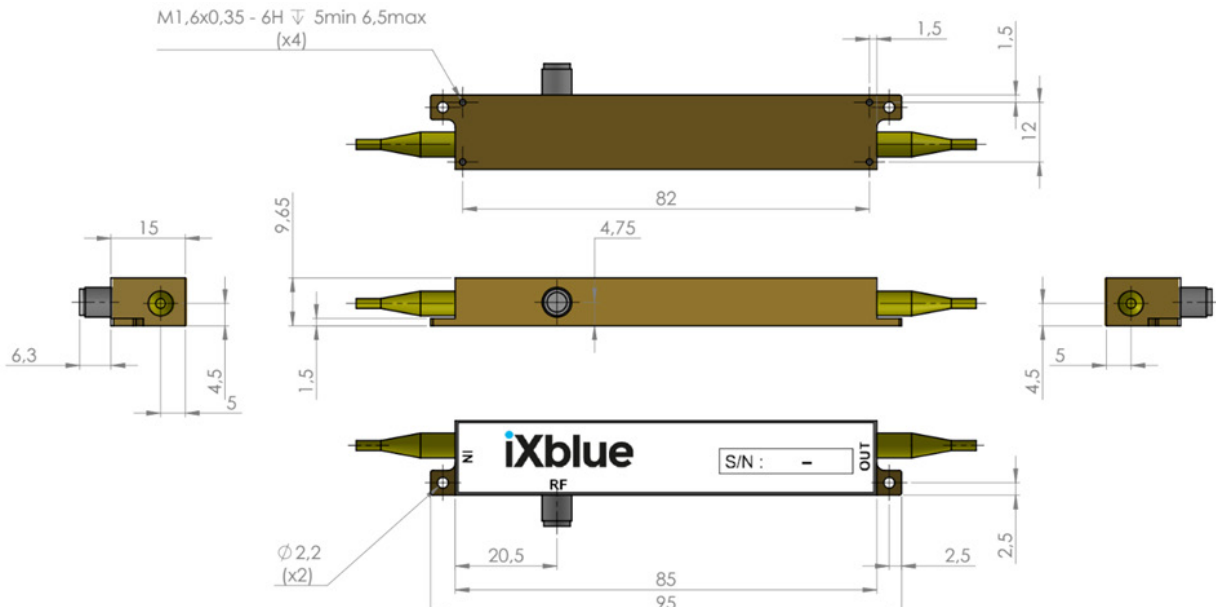

Port	Function	Note
IN	Optical input port	Polarization maintaining 1550 nm Corning PM 15-U25D length : 1.5 meter, buffer diameter : 900 um
OUT	Optical output port	Polarization maintaining 1550 nm Corning PM 15-U25D length : 1.5 meter, buffer diameter : 900 um
RF	RF input port	Wiltron female K (V type for MPZ-LN-40)

Ordering information

MPX-LN-0.1-Y-Z-AB-CD / MPZ-LN-WW-Y-Z-AB-CD

XX = X-cut Bandwidth: 0.1 150 MHz  
 WW = Z-cut Bandwidth : 01 01 GHz 10 10 GHz 20 20 GHz 40 40 GHz  
 Y = Input fiber : P Polarization maintaining S Standard single mode  
 Z = Output fiber : P Polarization maintaining S Standard single mode  
 AB = Input connector : 00 bare fiber FA FC/APC FC FC/SPC  
 CD = Output connector : 00 bare fiber FA FC/APC FC FC/SPC  
 Note : optical connectors are Senko with narrow key or equivalent

About us

ixBlue Photonics produces specialty optical fibers and Bragg gratings based fiber optics components and provides optical modulation solutions based on the company lithium niobate (LiNbO<sub>3</sub>) modulators and RF electronic modules.

ixBlue Photonics serves a wide range of industries: sensing and instruments, defense, telecommunications, space and fiber lasers as well as research laboratories all over the world.