

Product Specification

M7100DA Dual-Stage Variable Gain EDFA, 20.5 dBm, 25-37 dB, with Mid-stage Access

PN: FOA-M7100DA-EVG2C-AA013

Document No.: 1213707 Revision: A00

Date: 01-Apr-14

Customer: General

Product Features

- Variable Gain EDFA with control electronics
- APC or AGC control modes
- Flat spectrum over gain range of 17-32 dB
- Output power up to 20.5 dBm
- Low noise figure
- Mid-stage access 4-9dB
- 100x150x18 package (without heat sink)
- Standard command protocol according to IEC 61291-6-1
- Low power dissipation
- RoHS compliant and lead free
- Class 1M* laser safety classification



Applications

- Regional, metro and access DWDM networks
- ROADM line cards
- Booster, pre-amp or inline

The M7100DA VG (Variable Gain) EDFA is a micro-processor-controlled module for C-band amplification. The module contains two amplification stages and has mid-stage access. The amplifier quickly reacts to network conditions as they unfold, seamlessly adjusting to variances in the system conditions of Metro and Long Haul environments in real-time. It can accommodate a wide variety of network topologies, fiber spans and fiber losses, thereby reducing the number of amplifier types needed for deployment in any given network environment.

The amplifier provides gain flattening and low noise figure in all its operational regimes. Its fast AGC allows the amplifier to keep the gain constant also in cases when there is a fast and large change in the input power.

Optical Specifications

Parameters	Min	Typ.	Max	Unit	Notes
Number of Pump Lasers	2				
Minimum Wavelength range in vacuum (C-Band)	1529.5		1564	nm	
Total Input Power (with fast transient suppression)	-37.0		-3.5	dBm	
Total Input Power (without fast transient suppression)	-40.0		-37.0	dBm	
Total SIGNAL Output Power (does not include ASE power)	-2		20.5	dBm	Max output power for single channel operation is +18dBm; Power for High Gain Zone is +18.5dBm. For gains 32-37: 0.2dB lower to keep total output lower than 20.8dBm
Mid Stage Input Power (does not include ASE power)	-13		11	dBm	
Mid-stage Loss, including connectors	4		9	dB	
Gain, 4-9 dB Mid-stage loss	25		37	dB	
Gain, High gain Zone.	37		40	dB	
Gain Setting Accuracy		±0.25	± 0.4	dB	
Gain Flatness over entire gain bandwidth (Pk-Pk)		0.7	1.2	dB	Gain flatness is defined at powers < 14dBm. At higher output powers linear negative tilt is created, so gain flattening is kept at < 1.2dB relative to the linear tilt.
Steady State Gain, Power Stability		± 0.1	±0.2	dB	
Noise Figure 4-9 dB mid-stage loss, including connector loss	G≥25dB, TILT=0		7.2	dB	All operating conditions Tilt=0
	G≥28dB, TILT=0		6.4		
	G≥30dB, TILT=0		6.1		
Adjustable Gain Tilt over G=25–37dB	-3.5		0	dB	
Overshoot/Undershoot for 16dB Add/Drop transient			±1.5	dB	
Stabilization Time after transient			500	µsec	
Residual Pump Power out of Input port			-30	dBm	

Parameters	Min	Typ.	Max	Unit	Notes
Residual Pump Power out of Output port			-20	dBm	
Optical Return Loss (at any port, pump off)	45			dB	
Polarization Dependence Loss			0.3	dB	
Polarization Mode Dispersion			0.2	ps	
Input Output Isolation	30			dB	
Output Monitor Ratio		1% (-20)		% (dB)	

Optical Ports

The VG EDFA module is equipped with five optical ports as described in the following drawing and table:

Port	Description	Adaptor Type	Pigtail Length cm	Shrink Color
Input	Input into first stage	LC	100+/-10	Black
Mid stage IN	Output of first Stage	LC	100+/-10	Red
Mid stage OUT	Input into second stage	LC	100+/-10	Yellow
Output	Output of second Stage	LC	100+/-10	White
Output Monitor	1% Output tap at second stage	LC	100+/-10	Blue

Electrical Parameters and Maximum Ratings

The following table summarizes the maximum electrical ratings of the amplifier

Parameter	Units	Specification			Notes
		Min.	Typ.	Max.	
Supply voltage	V	4.75	5.0	5.25	Power supply is fully isolated and no surges or spikes are allowed at input voltage.
Stead State Current	A			3.5	
Startup Current	A			8	
Power consumption	W			17	

Electrical Pin Out

Connector type: SAMTEC: ZLTMM- 125-XX-L- D – XXX

Pin no.	Function	Description	Pin no.	Function	Description
1	+ 5.0 V	Power Supply	2	+ 5.0 V	Power Supply
3	+ 5.0 V	Power Supply	4	+ 5.0 V	Power Supply
5	+ 5.0 V	Power Supply	6	+ 5.0 V	Power Supply
7	Ground		8	Ground	
9	Ground		10	Ground	
11	N/C		12	N/C	

Pin no.	Function	Description	Pin no.	Function	Description
13	Ground		14	RESET Input	LVTTL Input, Idle High, P.U 10K (1)
15	1 RS-232 Input, Rx	LVTTL Level 4.75K P.U	16	1 RS-232 Output, Tx	LVTTL Level Output, 4.75K P.U
17	Pumps Current Alarm	LVTTL Output, Active High	18	Loss of Input Alarm (1 st stage)	LVTTL Output, Active High
19	Ground		20	Ground	
21	N/C		22	N/C	
23	N/C		24	N/C	
25	Ground		26	N/C	
27	Loss of Input Alarm (2 nd stage)	LVTTL Output, Active High	28	Eye-safety Alarm	LVTTL Output, Active High
29	Loss of Output/Gain Alarm (2 nd stage)	LVTTL Output, Active High	30	Output Back-Reflection	LVTTL Output, Active High
31	Ground		32	Ground	
33	Case Temperature Alarm	LVTTL Output, Active High	34	Loss of Output/Gain Alarm (1 st stage)	LVTTL Output, Active High
35	Pumps Temperature Alarm	LVTTL Output, Active High	36	Valid/ Absent module alarm	LVTTL Output, Active High, Pull Up 5K
37	Shutdown Input	LVTTL Input, Active High 10K P.U	38	N/C	
39	N/C		40	N/C	
41	Ground		42	Ground	
43	Ground		44	Ground	
45	+ 5.0 V		46	+ 5.0 V	
47	+ 5.0 V		48	+ 5.0 V	
49	+ 5.0 V		50	+ 5.0 V	

Mechanical Diagram

EDFA is packaged in an aluminum box. EDFA drawings:

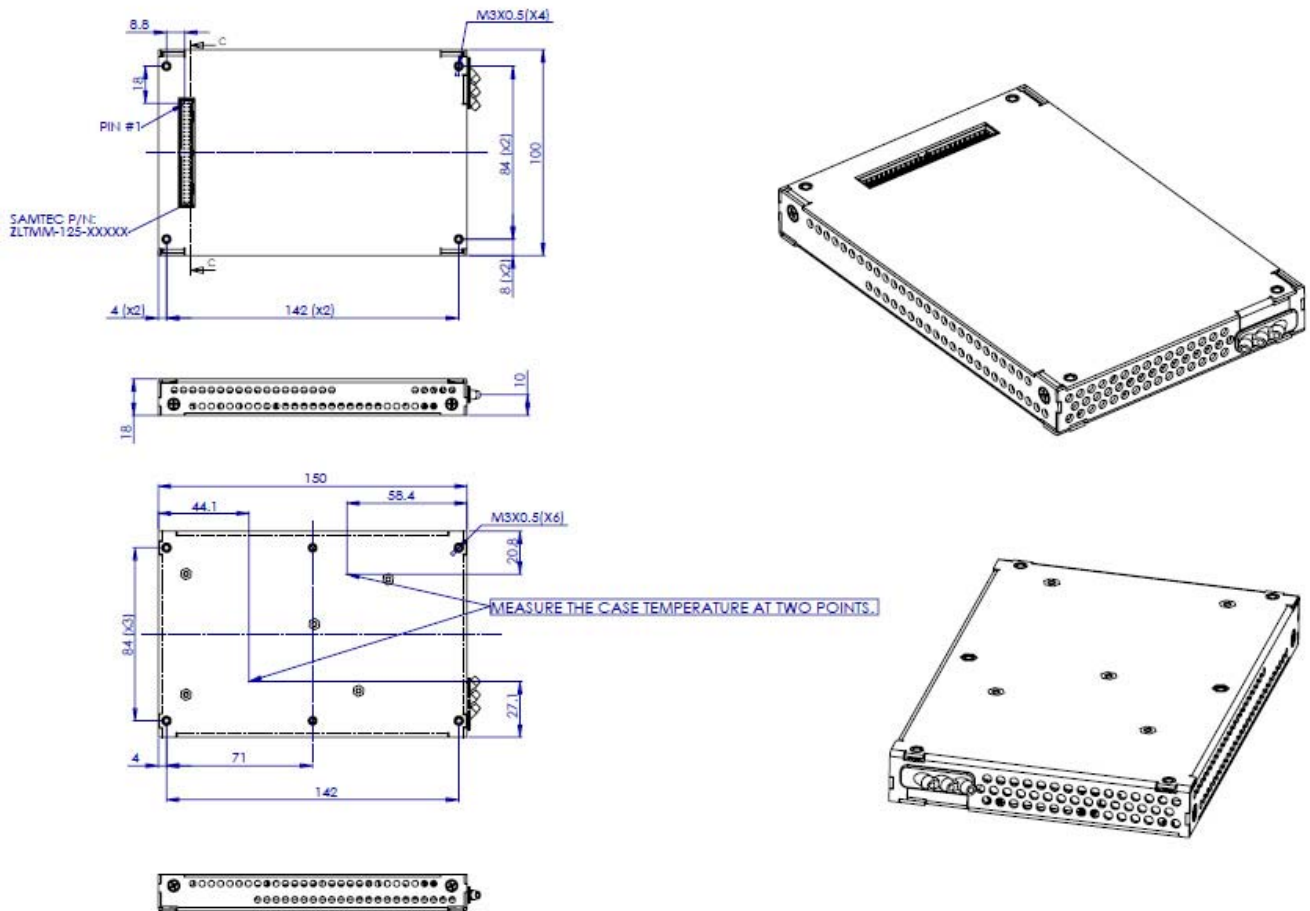

To the EDFA box a heat sink will be connected. Thermal paste will be added between amplifier and Heat-sink to assure good thermal connectivity.

Heat-sink drawing:

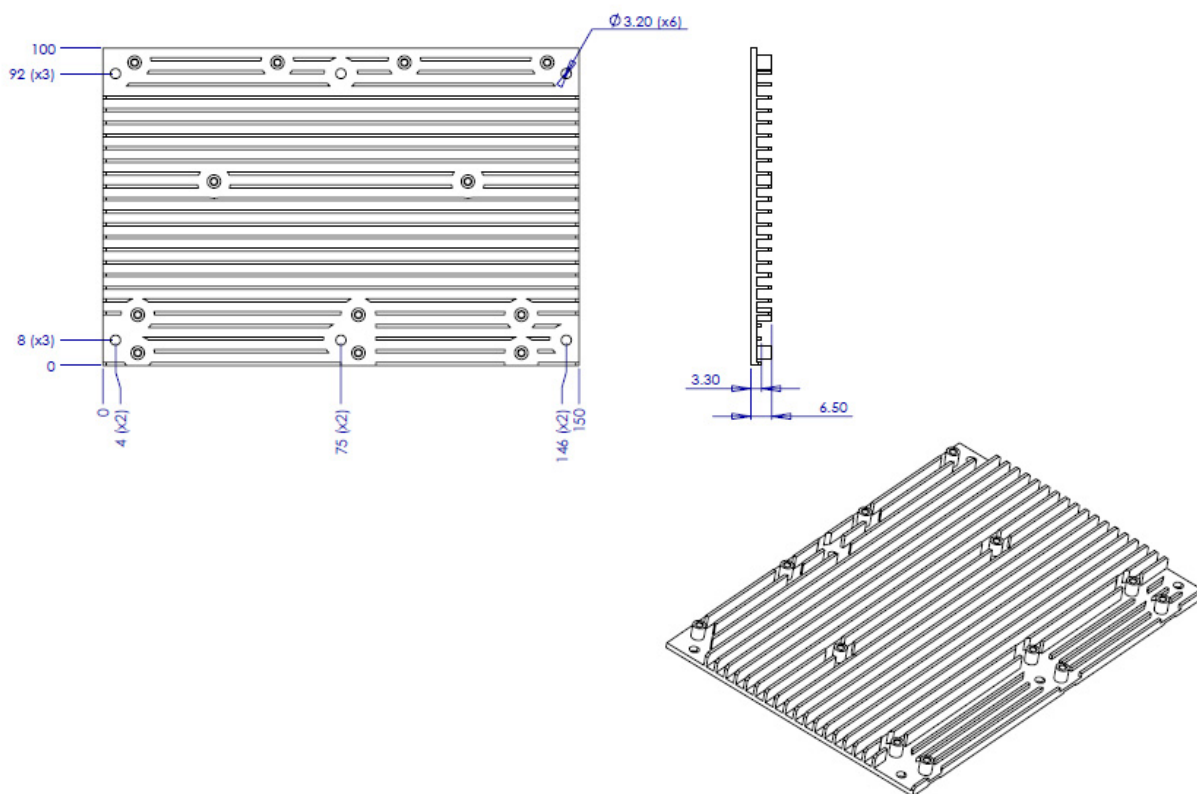

Environmental and Qualification

Parameter	Value/Range
Operating Case Temperature	0°C to +70 °C
Operating Humidity	5 to 85%
Storage Temperature	-40°C to +85°C
Storage Humidity	5 to 95%
Qualification	Telcordia GR1312
Laser Safety	Class 1M*

* Class 1M products are not hazardous under normal circumstances, but may pose an eye hazard when the laser output is viewed with certain optical instruments (for example eye loupes, magnifiers and microscopes) within a distance of 100 mm

Ordering Information:



800 Village Walk #316
 Guilford, CT 06437
 Ph: 203-401-8093

Email orders to: sales@xsoptix.com
 Fax orders to: 800-878-7282