

EYP-RWL-0808-00800-4000-BFW09-0000

Revision 1.00

10.11.2020

SINGLE MODE LASER DIODES Fabry-Perot Laser

General Product Information

Product	Application
808 nm Fabry-Perot Laser with hermetic Butterfly Package	Metrology
Monitor Diode, Thermoelectric Cooler and Thermistor	
Beam Collimation	
RoHS compliant	

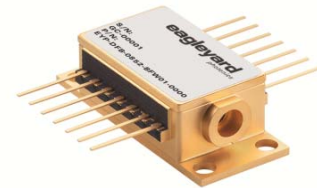

Absolute Maximum Ratings

Parameter	Symbol	Unit	min	typ	max
Storage Temperature	T_S	°C	-40		85
Operational Temperature at Case	T_C	°C	-20		75
Operational Temperature at Laser Chip	T_{LD}	°C	10		40
Forward Current	I_F	A			1.6
Reverse Voltage	V_R	V			2
Output Power	P_{opt}	mW			900
TEC Current	I_{TEC}	A			1.5
TEC Voltage	V_{TEC}	V			5.5

Measurement Conditions / Comments

Stress in excess of one of the Absolute Maximum Ratings can cause permanent damage to the device. Do not exceed the maximum optical output power or maximum forward current, whichever occurs first.

Recommended Operational Conditions

Parameter	Symbol	Unit	min	typ	max
Operational Temperature at Case	T_C	°C	0		40
Operational Temperature at Laser Chip	T_{LD}	°C	20	25	30
Forward Current	I_F	A		1.0	1.5
Output Power	P_{opt}	mW			800

Measurement Conditions / Comments

Characteristics at $T_{LD} = 25^\circ \text{C}$ at Begin Of Life

Parameter	Symbol	Unit	min	typ	max
Center Wavelength	λ_c	nm	796	808	816
Spectral Width (FWHM)	$\Delta\lambda$	nm		1	3
Temperature Coefficient of Wavelength	$d\lambda / dT$	nm / K		0.28	
Threshold Current	I_{th}	A			0.3
Output Power @ $I_F = 1.5 \text{ A}$	P_{opt}	mW	800		

Measurement Conditions / Comments

$P_{opt} = 800 \text{ mW}$, multi mode emission

EYP-RWL-0808-00800-4000-BFW09-0000

Revision 1.00

10.11.2020

SINGLE MODE LASER DIODES Fabry-Perot Laser

Characteristics at $T_{LD} = 25^{\circ} \text{C}$ at Begin Of Life

Parameter	Symbol	Unit	min	typ	max
Divergence parallel ($1/e^2$)	$\Theta_{ }$	$^{\circ}$		0.1	0.15
Divergence perpendicular ($1/e^2$)	Θ_{\perp}	$^{\circ}$		0.1	0.15
Divergence Ratio	$\Theta_{\perp} / \Theta_{ }$		0.66		1.5
Beam Diameter parallel ($1/e^2$)	$d_{ }$	mm		1	1.5
Beam Diameter perpendicular ($1/e^2$)	d_{\perp}	mm		1	1.5
Aspect Ratio of Beam Diameters	$d_{ } / d_{\perp}$		0.66		1.5
Beam propagation factor	M^2			1.2	1.5
Polarization Extinction Ratio	DOP	%		90	

Measurement Conditions / Comments

full angle, parallel to base plate (see p. 3)
full angle, perpendicular to base plate (see p. 3)
parallel to base plate (see p. 3)
perpendicular to base plate (see p. 3)
E field perpendicular to base plate (see p. 3)

EYP-RWL-0808-00800-4000-BFW09-0000

Revision 1.00

10.11.2020

SINGLE MODE LASER DIODES Fabry-Perot Laser

Monitor Diode

Parameter	Symbol	Unit	min	typ	max
Monitor Detector Responsivity	I_{mon}	μA	10		1000

Measurement Conditions / Comments

 $U_R = 5 \text{ V}; P_{\text{opt}} = 800 \text{ mW}$

Thermoelectric Cooler

Parameter	Symbol	Unit	min	typ	max
Current	I_{TEC}	A	0.3	0.9	1.5
Voltage	U_{TEC}	V	1.0	4	5.5
Power Dissipation (total loss at case)	P_{loss}	W	1.8	2.1	2.5
Temperature Difference	ΔT	K			30

Measurement Conditions / Comments

 $P_{\text{opt}} = 800 \text{ mW}, \Delta T = 30 \text{ K}$
 $P_{\text{opt}} = 800 \text{ mW}, \Delta T = 30 \text{ K}$
 $P_{\text{opt}} = 800 \text{ mW}, \Delta T = 30 \text{ K}$
 $P_{\text{opt}} = 800 \text{ mW}, \Delta T = |T_{\text{case}} - T_{\text{LD}}|$

Thermistor (Standard NTC Type)

Parameter	Symbol	Unit	min	typ	max
Resistance	R	$\text{k}\Omega$		10	
Beta Coefficient	β			3892	
Steinhart & Hart Coefficient	A			1.1293×10^{-3}	
Steinhart & Hart Coefficient	B			2.3410×10^{-4}	
Steinhart & Hart Coefficient	C			8.7755×10^{-8}	

Measurement Conditions / Comments

 $T = 25^\circ \text{ C}$
 $R_1 / R_2 = e^{\beta(1/T_1 - 1/T_2)}$ at $T = 0^\circ \dots 50^\circ \text{ C}$
 $1/T = A + B(\ln R) + C(\ln R)^3$

T: temperature in Kelvin

R: resistance at T in Ohm

EYP-RWL-0808-00800-4000-BFW09-0000

Revision 1.00

10.11.2020

SINGLE MODE LASER DIODES Fabry-Perot Laser

Package Dimensions

Parameter	Symbol	Unit	min	typ	max
Height of Emission Plane	h_{EP}	mm		4.9	

Measurement Conditions / Comments

Package Pinout

1	Thermoelectric Cooler (+)	14	Thermoelectric Cooler (-)
2	not connected	13	Case
3	not connected	12	not connected
4	not connected	11	Laser Diode (Cathode)
5	not connected	10	Laser Diode (Anode)
6	Thermistor	9	Photodiode (Anode)
7	Thermistor	8	Photodiode (Cathode)

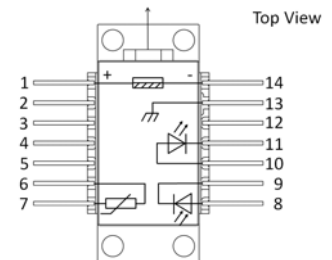

Package Drawings

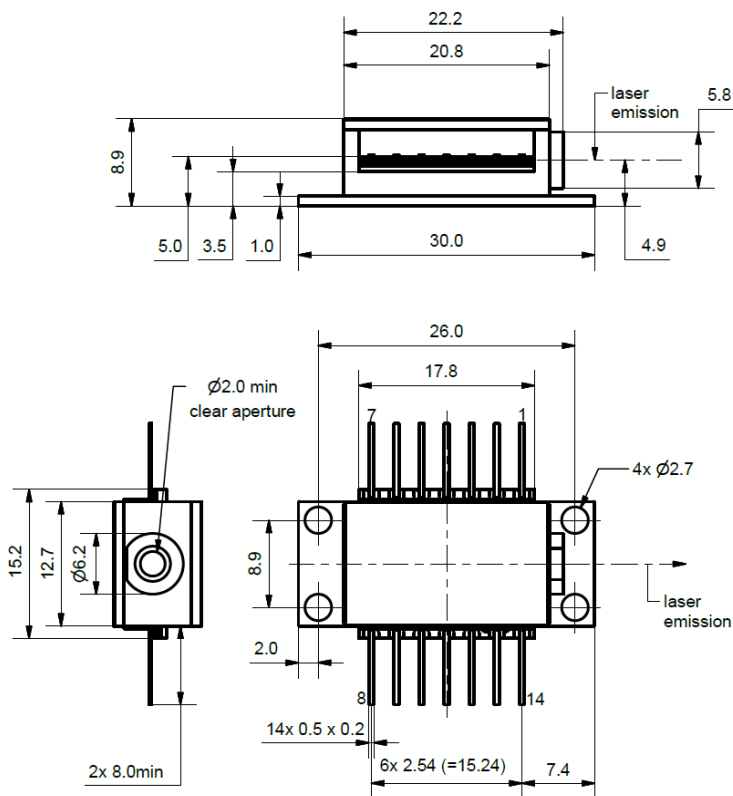

Polarization:

E field perpendicular to base plate

AIZ-20-1029-0928

EYP-RWL-0808-00800-4000-BFW09-0000

Revision 1.00

10.11.2020

SINGLE MODE LASER DIODES Fabry-Perot Laser

Unpacking, Installation and Laser Safety

Unpacking the laser diodes should only be done at electrostatic safe workstations (EPA). Though protection against electro static discharge (ESD) is implemented in the laser package, charges may occur at surfaces. Please store this product in its original package at a dry, clean place until final use. During device installation, ESD protection has to be maintained.

Operating at moderate temperatures on proper heat sinks will contribute to a long lifetime of the diode.

The laser emission from this diode is close to the invisible infrared region of the electromagnetic spectrum. Avoid direct and/or indirect exposure to the free running beam. Collimating the free running beam with optics as common in optical instruments will increase threat to the human eye.

Each laser diode will come with an individual test protocol verifying the parameters given in this document.

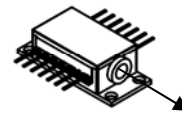

Laser Emission



Ordering Information:



800 Village Walk #316
Guilford, CT 06437
Ph: 203-401-8093

Email orders to: sales@xsoptix.com
Fax orders to: 800-878-7282