

EYP-RWS-1064-00080-1500-TOC03-0000

Revision 1.00

15.04.2016

SINGLE FREQUENCY LASER DIODES Stabilized Ridge Waveguide Laser

General Product Information

Product	Application
1064 nm Wavelength Stabilized Laser with narrow Linewidth (< 0.1 pm) sealed TO Housing with Monitor Diode, Thermoelectric Cooler and Thermistor	Metrology

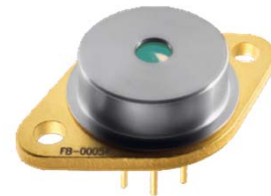

Absolute Maximum Ratings

Parameter	Symbol	Unit	min	typ	max
Storage Temperature	T_S	°C	-40		85
Operational Temperature at Case	T_C	°C	-20		75
Operational Temperature at Laser Chip	T_{LD}	°C	10		50
Forward Current	I_F	mA			190
Reverse Voltage	V_R	V			2
Output Power	P_{opt}	mW			90
TEC Current	I_{TEC}	A			1.8
TEC Voltage	V_{TEC}	V			3.2

Measurement Conditions / Comments

Stress in excess of one of the Absolute Maximum Ratings can cause permanent damage to the device. Please note that a damaging optical power level may occur although the maximum current is not reached.

Recommended Operational Conditions

Parameter	Symbol	Unit	min	typ	max
Operational Temperature at Case	T_{case}	°C	-20		65
Operational Temperature at Laser Chip	T_{LD}	°C	15		40
Forward Current	I_F	mA			170
Output Power	P_{opt}	mW	20		80

Measurement Conditions / Comments

measured with integrating sphere

Characteristics at 25° C at Begin Of Life

Parameter	Symbol	Unit	min	typ	max
Center Wavelength	λ_c	nm	1062	1064	1066
Selectable Line Width	$\Delta\lambda$	pm			0.1
Overall Line Width	$\Delta\lambda$	nm			0.2
Temperature Coefficient of Wavelength	$d\lambda / dT$	nm / K		0.06	
Current Coefficient of Wavelength	$d\lambda / dI$	nm / mA		0.003	
Output Power @ $I_F : 170$ mA	P_{opt}	mW	80		
Slope Efficiency	η	W / A	0.6	0.8	1.1

Measurement Conditions / Comments

single mode operation (see p. 4)

multi mode operation (see p. 4)

measured with integrating sphere

EYP-RWS-1064-00080-1500-TOC03-0000

Revision 1.00

15.04.2016

SINGLE FREQUENCY LASER DIODES Stabilized Ridge Waveguide Laser



Characteristics at 25° C at Begin Of Life cont'd

Parameter	Symbol	Unit	min	typ	max
Threshold Current	I_{th}	mA			70
Divergence parallel (FWHM)	$\Theta_{ }$	°		8	
Divergence perpendicular (FWHM)	Θ_{\perp}	°		21	
Degree of Polarization	DOP	%		90	
Spatial Mode (transversal)				TEM ₀₀	

Measurement Conditions / Comments

parallel to short axis of housing (see p. 3)
parallel to long axis of housing (see p. 3)
 $P_{opt} = 80$ mW; E field parallel to short axis of housing
fundamental mode

Monitor Diode

Parameter	Symbol	Unit	min	typ	max
Monitor Detector Responsivity	I_{mon} / P_{opt}	$\mu A / mW$	0.5		10

Measurement Conditions / Comments

$U_R = 5$ V

Thermoelectric Cooler

Parameter	Symbol	Unit	min	typ	max
Current	I_{TEC}	A		0.4	
Voltage	U_{TEC}	V		0.8	
Power Dissipation (total loss at case)	P_{loss}	W		0.5	
Temperature Difference	ΔT	K			50

Measurement Conditions / Comments

$P_{opt} = 80$ mW, $\Delta T = 20$ K
 $P_{opt} = 80$ mW, $\Delta T = 20$ K
 $P_{opt} = 80$ mW, $\Delta T = 20$ K
 $P_{opt} = 80$ mW, $\Delta T = |T_{case} - T_{LD}|$

Thermistor (Standard NTC Type)

Parameter	Symbol	Unit	min	typ	max
Resistance	R	k Ω		10	
Beta Coefficient	β			3892	
Steinhart & Hart Coefficient	A			1.1293×10^{-3}	
Steinhart & Hart Coefficient	B			2.3410×10^{-4}	
Steinhart & Hart Coefficient	C			8.7755×10^{-8}	

Measurement Conditions / Comments

$T = 25^{\circ} C$
 $R_1 / R_2 = e^{\beta(1/T_1 - 1/T_2)}$ at $T = 0^{\circ} \dots 50^{\circ} C$
 $1/T = A + B(\ln R) + C(\ln R)^3$
T: temperature in Kelvin
R: resistance at T in Ohm

EYP-RWS-1064-00080-1500-TOC03-0000

Revision 1.00

15.04.2016

SINGLE FREQUENCY LASER DIODES Stabilized Ridge Waveguide Laser

Package Dimensions

Parameter	Symbol	Unit	min	typ	max
Height of Laser Output above Header	H_L	mm		5.1	
Housing Dimension	$l \times w \times h$	mm ³		38.9 x 25.4 x 9.3	
Pin Length	L	mm	10.8		

Measurement Conditions / Comments

Package Pinout

1	Thermoelectric Cooler (+)	5	Laser Diode Anode
2	Thermistor	6	Monitor Diode Anode
3	Thermistor	7	Photo Diode Cathode
4	Laser Diode Cathode	8	Thermoelectric Cooler (-)

bottom view

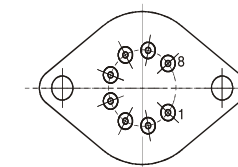

all pins are isolated from case

Package Drawings

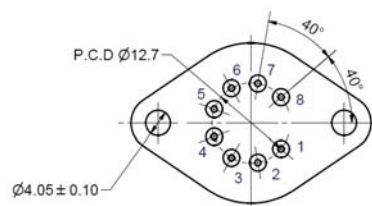
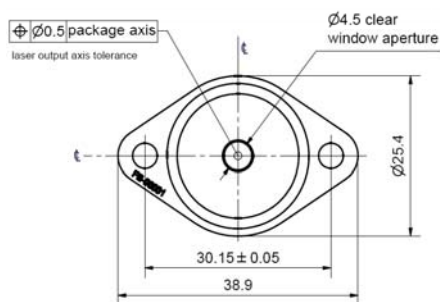
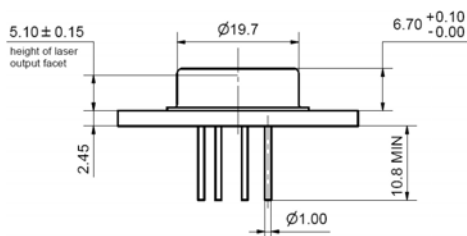

Polarization:

E field parallel to long axis of housing

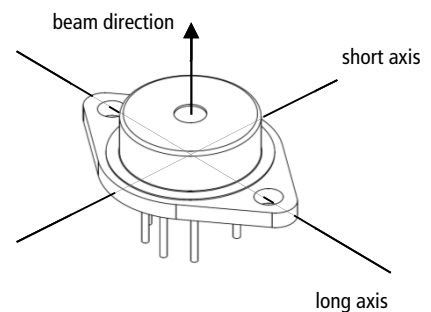

Z11-SPEC-TOC03-DFB-0000

EYP-RWS-1064-00080-1500-TOC03-0000

Revision 1.00

15.04.2016

SINGLE FREQUENCY LASER DIODES Stabilized Ridge Waveguide Laser

Typical Measurement Results

Spectral maps at 25° C and 35° C

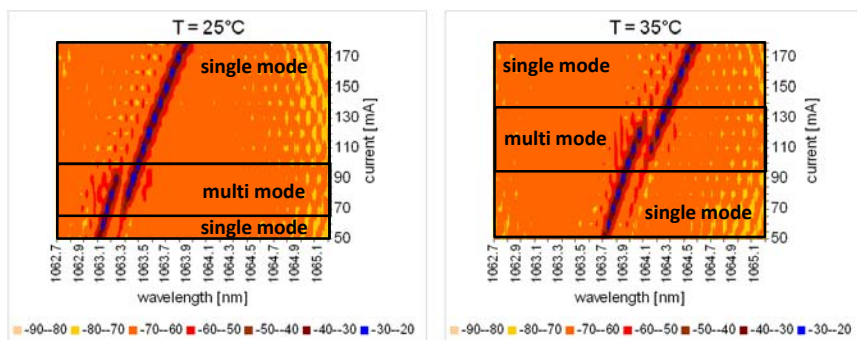

The spectral maps show the power spectral density at different operating modes. The graphs illustrate that the laser exhibits single and multi mode behavior under different operational conditions. The spectral maps may differ from part to part. Single mode operation can be achieved by selecting the appropriate laser current and temperature.

Unpacking, Installation and Laser Safety

Unpacking the laser diodes should only be done at electrostatic safe workstations (EPA). Though protection against electro static discharge (ESD) is implemented in the laser package, charges may occur at surfaces. Please store this product in its original package at a dry, clean place until final use. During device installation, ESD protection has to be maintained.

The RWS laser is sensitive against optical feedback, so an optical isolator may be required in order to avoid any disturbance of the emission spectrum. Operating at moderate temperatures on proper heat sinks will contribute to a long lifetime of the diode.

The laser emission from this diode is close to the invisible infrared region of the electromagnetic spectrum. Avoid direct and/or indirect exposure to the free running beam. Collimating the free running beam with optics as common in optical instruments will increase threat to the human eye.

Each laser diode will come with an individual test protocol verifying the main parameters given in this document. It does not include the detailed spectral maps which are shown above in order to illustrate the spectral behavior of this laser type.

Performance figures, data and any illustrative material provided in this specification are typical and must be specifically confirmed in writing by eagleyard Photonics before they become applicable to any particular order or contract. In accordance with the eagleyard Photonics policy of continuous improvement specifications may change without notice.

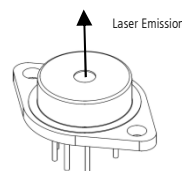

Ordering Information:



800 Village Walk #316
Guilford, CT 06437
Ph: 203-401-8093

Email orders to: sales@xsoptix.com
Fax orders to: 800-878-7282