

EYP-RWS-0785-00080-1500-SOT02-0000



We focus on power.

Revision 0.90 2012-02-17 page 1 from 4

STABILIZED RIDGE WAVEGUIDE LASER

Wavelength Stabilized
GaAs Semiconductor Laser Diode



General Product Information

Product	Application
1064 nm Wavelength Stabilized Laser	Metrology
with narrow Linewidth (< 1 pm)	Raman Spectroscopy
sealed SOT Housing	
Monitor Diode	

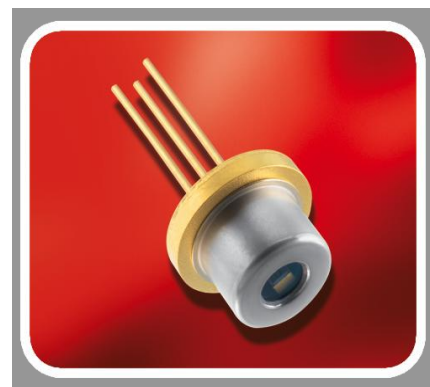

Absolute Maximum Ratings

	Symbol	Unit	min	typ	max
Storage Temperature	T_S	°C	-40		85
Operational Temperature at Case	T_C	°C	-20		75
Forward Current	I_F	mA			190
Reverse Voltage	V_R	V			2
Output Power (extracavity)	P_{opt}	mW			90

Stress in excess of one of the Absolute Maximum Ratings can cause permanent damage to the device. Please note that a damaging optical power level may occur although the maximum current is not reached.

Recommended Operational Conditions

	Symbol	Unit	min	typ	max
Operational Temperature at Case	T_{case}	°C	15		40
Forward Current	I_F	mA			170
Output Power	P_{opt}	mW	20		80

Measurement Conditions / Comments

total output power measured with integrating sphere

Characteristics at 25° C at Begin Of Life

Parameter	Symbol	Unit	min	typ	max
Center Wavelength	λ_c	nm	782	785	788
Selectable Line Width	$\Delta\lambda$	pm			1
Overall Line Width	$\Delta\lambda$	nm			0.2
Temperature Coefficient of Wavelength	$d\lambda / dT$	nm / K		0.06	
Current Coefficient of Wavelength	$d\lambda / dI$	nm / mA		0.003	
Output Power @ $I_F = 170$ mA	P_{opt}	mW	80		
Slope Efficiency	S	W / A	0.6	0.8	1.1
Threshold Current	I_{th}	mA			70

Measurement Conditions / Comments

tighter wavelength specification available on request
single mode operation (see p. 4)
multi mode operation (see p. 4)

measured with integrating sphere

EYP-RWS-0785-00080-1500-SOT02-0000



We focus on power.

Revision 0.90

2012-02-17

page 2 from 4

STABILIZED RIDGE WAVEGUIDE LASER

Wavelength Stabilized
GaAs Semiconductor Laser Diode



Characteristics at 25° C at Begin Of Life cont'd

Parameter	Symbol	Unit	min	typ	max
Divergence parallel (FWHM)	$\Theta_{ }$	°		8	
Divergence perpendicular (FWHM)	Θ_{\perp}	°		21	
Sidemode Supression Ratio	SMSR	dB	30	45	
Polarization Extinction Ratio @ $P_{opt} = 80$ mW	PER	dB		20	
Spatial Mode (transversal)				TEM ₀₀	

Measurement Conditions / Comments
parallel to Pin 2 - Pin 3 plane (see p. 3)
perpendicular to Pin 2 - Pin 3 plane (see p. 3)
under single mode condition
E field perpendicular to Pin 2 - Pin 3 - plane
fundamental mode

Monitor Diode

Parameter	Symbol	Unit	min	typ	max
Monitor Detector Responsivity	I_{mon} / P_{opt}	μA / mW	1		20
Reverse Voltage Monitor Diode	$U_{R MD}$	V	3		5

Measurement Conditions / Comments
$U_R = 5$ V

EYP-RWS-0785-00080-1500-SOT02-0000

Revision 0.90

2012-02-17

page 3 from 4

STABILIZED RIDGE WAVEGUIDE LASER

Wavelength Stabilized
GaAs Semiconductor Laser Diode



Package Dimensions

Parameter	Symbol	Unit	min	typ	max
Height of Emission Plane	d_{EP}	mm	3.50	3.65	3.70
Excentricity of Emission Center	R	mm			0.12
Pin Length	l_{PIN}	mm		14	

Measurement Conditions / Comments

reference plane: top side of TO header

reference: center of outer diameter of header

Package Pinout

Ground	1
Photo Diode (+)	2
Laser (+)	3

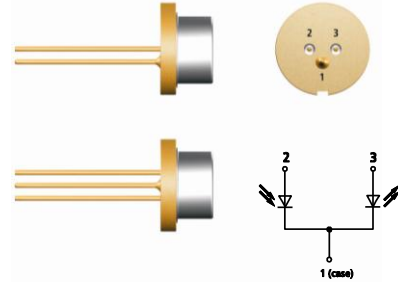

Package Drawings

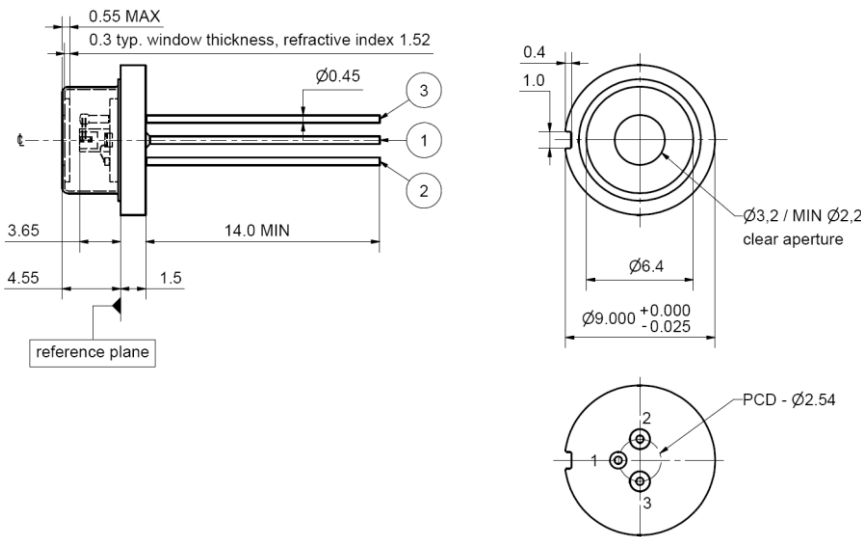

Z11-SPEC-SOT02-COM-000

EYP-RWS-0785-00080-1500-SOT2-0000

Revision 0.90

2012-02-17

page 4 from 4

STABILIZED RIDGE WAVEGUIDE LASER

Wavelength Stabilized
GaAs Semiconductor Laser Diode



Typical Measurement Results

Spectral maps at 25° C and 35° C

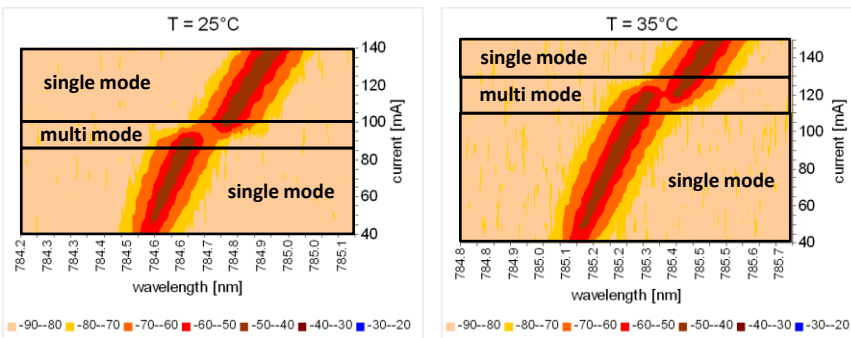

The spectral maps show the power spectral density at different operating modes. The graphs illustrate that the laser exhibits single and multi mode behavior under different operational conditions. The spectral maps may differ from part to part. Single mode operation can be achieved by selecting the appropriate laser current and temperature.

Ordering Information:



800 Village Walk #316
Guilford, CT 06437
Ph: 203-401-8093

Email orders to: sales@xsoptix.com
Fax orders to: 800-878-7282

Unpacking, Installation and Laser Safety

Unpacking the laser diodes should only be done at electrostatic safe workstations (EPA). Though protection against electro static discharge (ESD) is implemented in the laser package, charges may occur at surfaces. Please store this product in its original package at a dry, clean place until final use. During device installation, ESD protection has to be maintained.

The RWS laser is sensitive against optical feedback, so an optical isolator may be required in order to avoid any disturbance of the emission spectrum. Operating at moderate temperatures on proper heat sinks will contribute to a long lifetime of the diode.

The laser emission from this diode is close to the invisible infrared region of the electromagnetic spectrum. Avoid direct and/or indirect exposure to the free running beam. Collimating the free running beam with optics as common in optical instruments will increase threat to the human eye.

Each laser diode will come with an individual test protocol verifying the main parameters given in this document. It does not include the detailed spectral maps which are shown above in order to illustrate the spectral behavior of this laser type.

Performance figures, data and any illustrative material provided in this specification are typical and must be specifically confirmed in writing by eagleyard Photonics before they become applicable to any particular order or contract. In accordance with the eagleyard Photonics policy of continuous improvement specifications may change without notice.

